



# Product Specification

G185XW01 V1

AU OPTRONICS CORPORATION

- ( ) Preliminary Specification
- ( V ) Final Specification

<b>Module</b>	18.5" Color TFT-LCD
<b>Model Name</b>	G185XW01 V1

Customer	Date
_____	_____
<b>Approved by</b>	
_____	_____
Note: This Specification is subject to change without notice.	

Approved by	Date
<u>Vito Huang</u>	<u>2011/11/28</u>
<b>Prepared by</b>	
<u>Linda Lee</u>	<u>2011/11/28</u>
Desktop Display Business Group / AU Optronics corporation	

**Contents**

<b>1.0 Handling Precautions.....</b>	<b>4</b>
<b>2.0 General Description .....</b>	<b>5</b>
2.1 Display Characteristics.....	5
2.2 Optical Characteristics .....	6
<b>3.0 Functional Block Diagram .....</b>	<b>10</b>
<b>4.0 Absolute Maximum Ratings .....</b>	<b>11</b>
4.1 TFT LCD Module.....	11
4.2 Absolute Ratings of Environment.....	11
<b>5.0 Electrical characteristics.....</b>	<b>12</b>
5.1 TFT LCD Module.....	12
5.1.1 Power Specification.....	12
5.1.2 Signal Electrical Characteristics.....	13
5.2 Backlight Unit.....	14
<b>6.0 Signal Characteristic.....</b>	<b>15</b>
6.1 Pixel Format Image.....	15
6.2 The input data format .....	16
6.3 Signal Description .....	17
6.4 Timing Characteristics .....	19
6.5 Timing diagram.....	20
6.6 Power ON/OFF Sequence .....	21
<b>7.0 Connector &amp; Pin Assignment .....</b>	<b>22</b>
7.1 TFT LCD Module.....	22
7.2 LED Backlight Unit: LED Driver Connector .....	22
7.3 LED Driver Connector Pin Assignment.....	23
<b>8.0 Reliability Test. ....</b>	<b>24</b>
<b>9.0 Shipping Label &amp; Packaging.....</b>	<b>25</b>
9.1 Shipping Label.....	25
9.2 Packaging .....	26
<b>10.0 Mechanical Characteristics .....</b>	<b>27</b>



**Record of Revision**

Version & Date	Page	Old description	New Description						
0.1 2011/05/13	All	First Edition for Customer	N/A						
0.2 2011/06/13	5	Power Consumption: 14.6W (Typ)	Power Consumption:15.3W (Typ)						
	14	Input Voltage: 5V	Input Voltage: 12V						
	14	Power Consumption: 4.5(Typ), 5.5 (Max).	Power Consumption: 10.8(Typ), 13.2 (Max).						
	21		Power ON/OFF Sequence Update						
1.0 2011/08/12	6	<b>Response Time</b>		<b>Resonse Time:</b>					
		Raising Time (T <sub>RR</sub> ) <sup>μ</sup>	- <sup>μ</sup>	3.8 <sup>μ</sup>	5.7 <sup>μ</sup>	Raising Time (T <sub>RR</sub> ) <sup>μ</sup>	- <sup>μ</sup>	3.5 <sup>μ</sup>	5 <sup>μ</sup>
		Falling Time (T <sub>RF</sub> ) <sup>μ</sup>	- <sup>μ</sup>	1.4 <sup>μ</sup>	2.3 <sup>μ</sup>	Falling Time (T <sub>RF</sub> ) <sup>μ</sup>	- <sup>μ</sup>	1.5 <sup>μ</sup>	2.5 <sup>μ</sup>
		Raising + Falling <sup>μ</sup>	- <sup>μ</sup>	5 <sup>μ</sup>	8 <sup>μ</sup>	Raising + Falling <sup>μ</sup>	- <sup>μ</sup>	5 <sup>μ</sup>	7.5 <sup>μ</sup>
1.0 2011/08/12	5 & 11	Operating Temperature: Max. +50°C	Operating Temperature: Max. +60°C (as surface temperature)						
1.0 2011/08/12	17,18,21 22,23		VDD & VCC Symbol correction						
1.0 2011/08/12	26		Add Packaging Info						
1.0 2011/08/12	28		Mechanical Drawing (Rear) Update						
1.1 2011/11/28	14	Unit of Dimming Frequency: [kHz]	[Hz]						

**1.0 Handling Precautions**

- 1) Since front polarizer is easily damaged, pay attention not to scratch it.
- 2) Be sure to turn off power supply when inserting or disconnecting from input connector.
- 3) Wipe off water drop immediately. Long contact with water may cause discoloration or spots.
- 4) When the panel surface is soiled, wipe it with absorbent cotton or other soft cloth.
- 5) Since the panel is made of glass, it may break or crack if dropped or bumped on hard surface.
- 6) Since CMOS LSI is used in this module, take care of static electricity and insure human earth when handling.
- 7) Do not open or modify the Module Assembly.
- 8) Do not press the reflector sheet at the back of the module to any directions.
- 9) In case if a Module has to be put back into the packing container slot after it was taken out from the container, do not press the center of LED lightbar edge. Instead, press at the far ends of the LED light bar edge softly. Otherwise the TFT Module may be damaged.
- 10) At the insertion or removal of the Signal Interface Connector, be sure not to rotate nor tilt the Interface Connector of the TFT Module.
- 11) After installation of the TFT Module into an enclosure, do not twist nor bend the TFT Module even momentarily. While designing the enclosure, it should be taken into consideration that no bending/twisting forces are applied to the TFT Module from outside. Otherwise the TFT Module may be damaged.
- 12) Small amount of materials having no flammability grade is used in the LCD module. The LCD module should be supplied by power complied with requirements of Limited Power Source (IEC60950 or UL1950), or be applied exemption.



## 2.0 General Description

This specification applies to the 18.5 inch-wide Color a-Si TFT-LCD Module G185XW01 V1. The display supports the WXGA [1366(H) x 768(V)] screen format and 16.7M colors (RGB 6-bits + Hi-FRC data). All input signals are LVDS interface compatible.

## 2.1 Display Characteristics

The following items are characteristics summary on the table under 25°C condition:

ITEMS	Unit	SPECIFICATIONS
Screen Diagonal	[mm]	470.1(18.51")
Active Area	[mm]	409.8 (H) x 230.4 (V)
Pixels H x V		1366(x3) x 768
Pixel Pitch	[um]	300 (per one triad) x 300
Pixel Arrangement		R.G.B. Vertical Stripe
Display Mode		TN Mode, Normally White
White Luminance ( Center )	[cd/m <sup>2</sup> ]	300 cd/m <sup>2</sup> (Typ.)
Contrast Ratio		1000 (Typ.)
Optical Response Time	[msec]	5ms (Typ., on/off)
Nominal Input Voltage VDD	[Volt]	+5.0 V (Typ)
Power Consumption (VDD line + LED line)	[Watt]	15.3W (Typ.) (P <sub>dd</sub> =4.5W, P <sub>LED</sub> =10.8W)
Weight	[Grams]	1820(Max)
Physical Size	[mm]	430.4 (W) x 254.6 (H) Typ. x 16.4(D)Typ
Electrical Interface		One channel LVDS
Support Color		16.7M colors, RGB 6-bit +Hi- FRC
Surface Treatment		Anti-Glare, 3H
Temperature Range		
Operating	[°C]	0 to +60
Storage (Shipping)	[°C]	-20 to +60
RoHS Compliance		RoHS Compliance



2.2 Optical Characteristics

The optical characteristics are measured under stable conditions at 25 °C:

Item	Unit	Conditions	Min.	Typ.	Max.	Note
Viewing Angle	[degree]	Horizontal (Right) CR = 10 (Left)	150	170	- -	2
		Vertical (Up) CR = 10 (Down)	140	160	- -	
Contrast ratio		Normal Direction	600	1000	-	3
Response Time	[msec]	Raising Time (T <sub>IR</sub> )	-	3.5	5	4
		Falling Time (T <sub>IF</sub> )	-	1.5	2.5	
		Raising + Falling	-	5	7.5	
Color / Chromaticity Coordinates (CIE)  Color Coordinates (CIE) White		Red x	0.583	0.633	0.683	5
		Red y	0.296	0.346	0.396	
		Green x	0.281	0.331	0.381	
		Green y	0.550	0.600	0.650	
		Blue x	0.098	0.148	0.198	
		Blue y	0.016	0.066	0.116	
		White x	0.263	0.313	0.363	
		White y	0.279	0.329	0.379	
Central Luminance	[cd/m <sup>2</sup> ]		240	300	-	6
Luminance Uniformity	[%]		65	70	-	7
Crosstalk (in 60Hz)	[%]				1.5	8
Flicker	dB				-20	9

**Note 1: Measurement method**

The LCD module should be stabilized at given temperature for 30 minutes to avoid abrupt temperature change during measuring (at surface 35°C). In order to stabilize the luminance, the measurement should be executed after lighting Backlight for 30 minutes in a stable, windless and dark room.

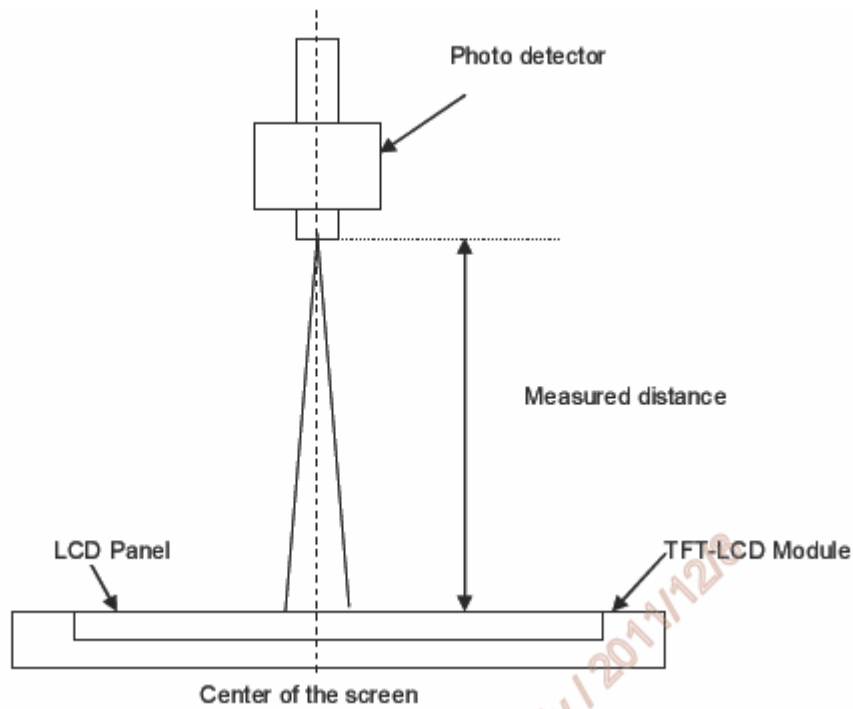

**Note 2: Definition of viewing angle measured by ELDIM (EZContrast 88)**

Viewing angle is the measurement of contrast ratio  $\geq 10$ , at the screen center, over a 180° horizontal and 180° vertical range (off-normal viewing angles). The 180° viewing angle range is broken down as follows; 90° ( $\theta$ ) horizontal left and right and 90° ( $\Phi$ ) vertical, high (up) and low (down). The measurement direction is typically perpendicular to the display surface with the screen rotated about its center to develop the desired measurement viewing angle.

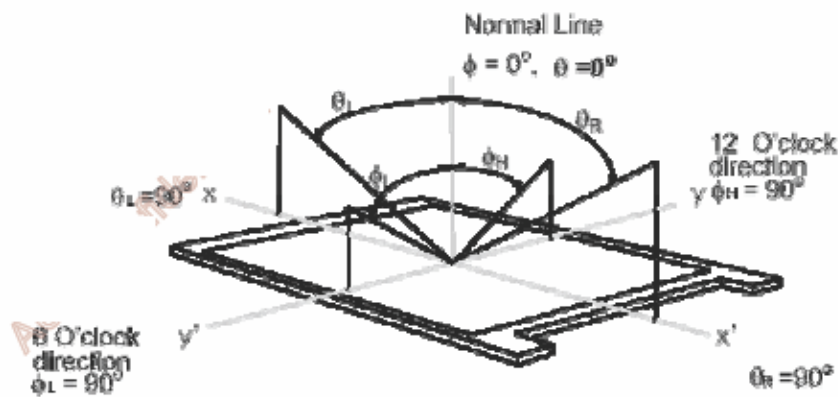

**Note 3: Contrast ratio is measured by TOPCON SR-3**

**Note 4: Definition of Response time measured by Westar TRD-100A**

The output signals of photo detector are measured when the input signals are changed from "Full Black" to "Full White" (rising time,  $T_{rR}$ ), and from "Full White" to "Full Black" (falling time,  $T_{rF}$ ), respectively. The response time is interval between the 10% and 90% (1 frame at 60 Hz) of amplitudes.  $T_{rR} + T_{rF} = 5 \text{ msec (typ.)}$ .

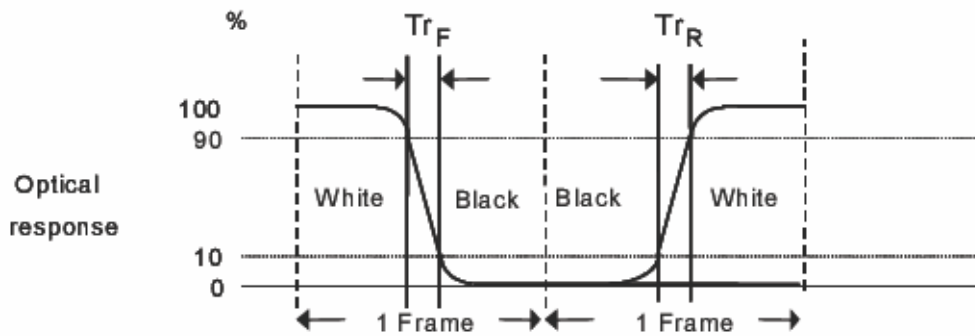

**Note 5: Color chromaticity and coordinates (CIE) is measured by TOPCON SR-3**

**Note 6: Central luminance is measured by TOPCON SR-3**

**Note 7: Luminance uniformity of these 9 points is defined as below and measured by TOPCON SR-3**

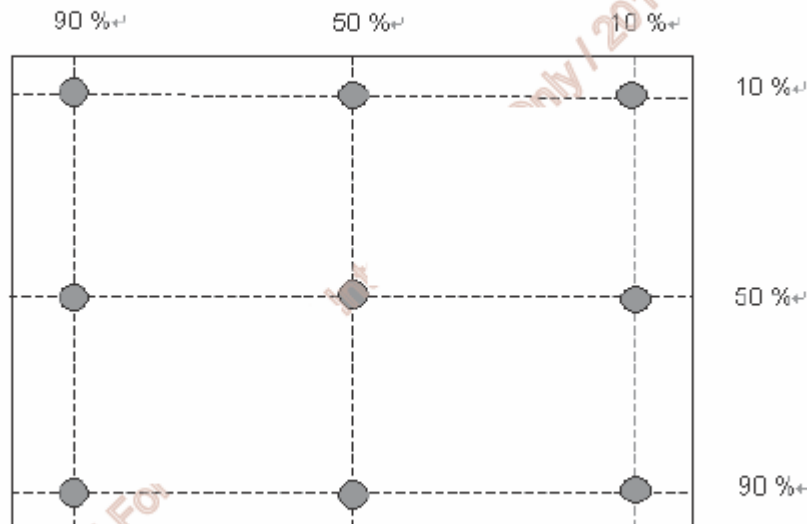

$$\text{Uniformity} = \frac{\text{Minimum Luminance in 9 points (1-9)}}{\text{Maximum Luminance in 9 Points (1-9)}}$$

**Note 8: Crosstalk is defined as below and measured by TOPCON SR-3**

$$CT = |YB - YA| / YA \times 100 (\%)$$

Where

YA = Luminance of measured location without gray level 0 pattern (cd/m<sup>2</sup>)

YB = Luminance of measured location with gray level 0 pattern (cd/m<sup>2</sup>)

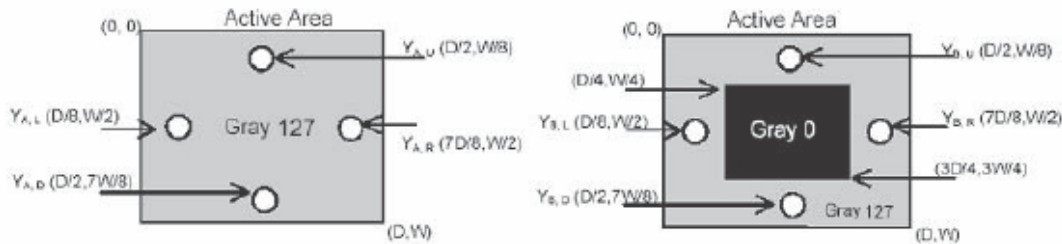

**Note 9: Test Pattern: Subchecker Pattern measured by TOPCON SR-3**

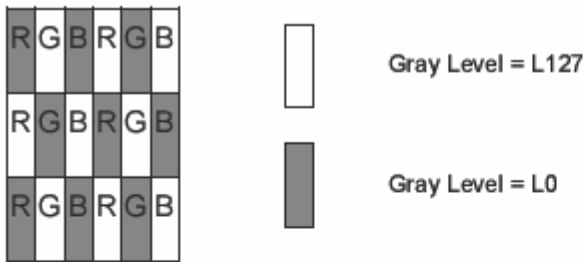

Method: Record dBV & DC value with TRD-100

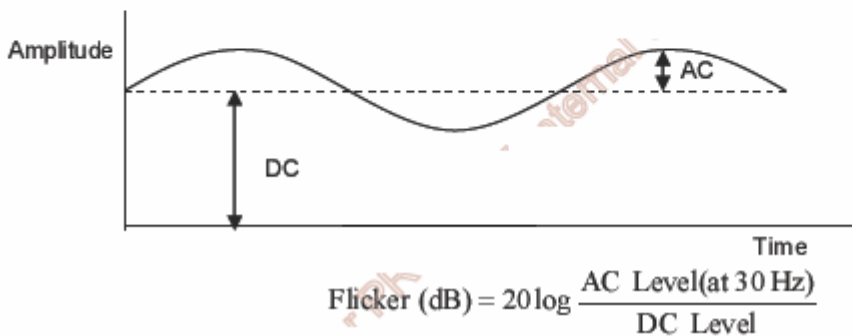

### 3.0 Functional Block Diagram

The following diagram shows the functional block of the 18.5 inch Color TFT-LCD Module:

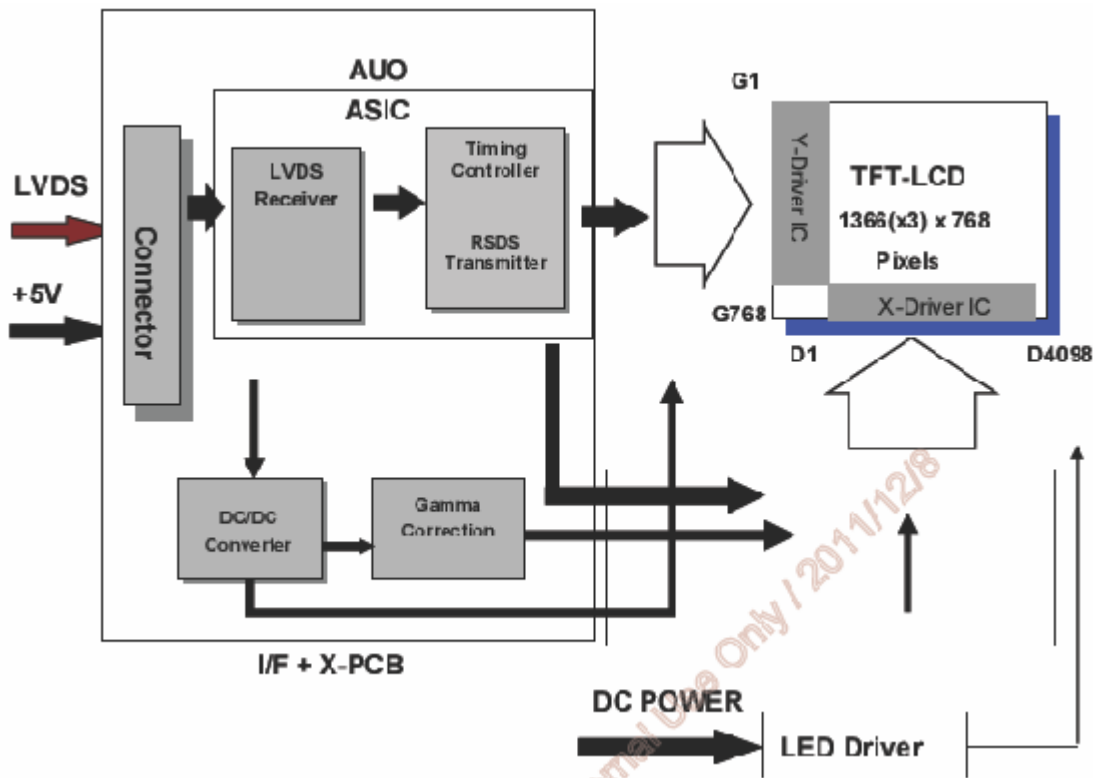

#### I/F PCB Interface:

FI-XB30SSRL-HF16(JAE)/MSCKT2407P30HB(信盛)

#### Mating Type:

FI-X30HL (JAE)(Locked Type)

**4.0 Absolute Maximum Ratings**

Absolute maximum ratings of the module are as following:

**4.1 TFT LCD Module**

Item	Symbol	Min	Max	Unit	Conditions
Logic/LCD Drive Voltage	VDD	4.5	+5.5	[Volt]	Note 1,2

**4.2 Absolute Ratings of Environment**

Item	Symbol	Min.	Max.	Unit	Conditions
Operating Temperature	TOP	0	+60	[°C]	Note 3 & 4
Operation Humidity	HOP	5	90	[%RH]	
Storage Temperature	TST	-20	+60	[°C]	
Storage Humidity	HST	5	90	[%RH]	

**Note 1:** With in Ta (25 °C)

**Note 2:** Permanent damage to the device may occur if exceeding maximum values

**Note 3:** For quality performance, please refer to AUO IIS(Incoming Inspection Standard).

**Note 4:** Operation Temperature + 60°C is defined as panel surface temperature.

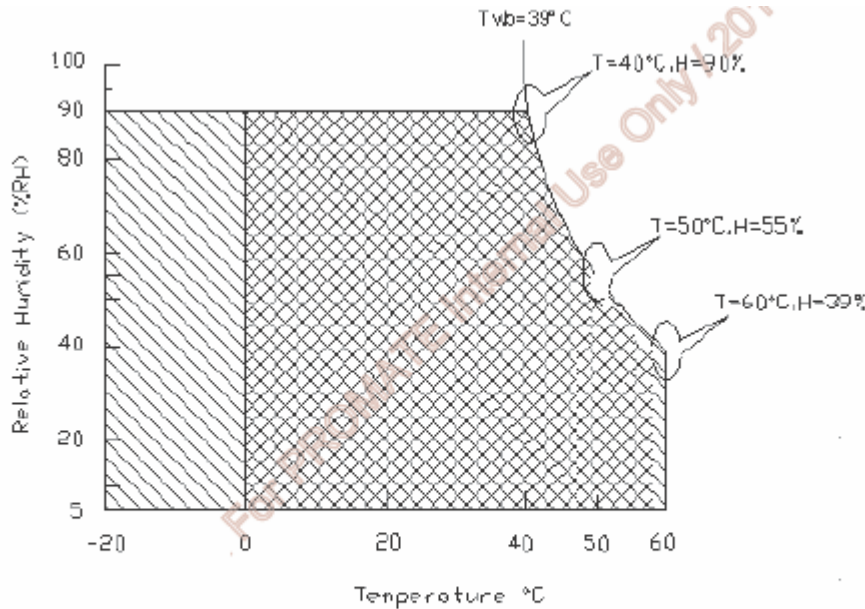

Operating Range



Storage Range



## 5.0 Electrical characteristics

### 5.1 TFT LCD Module

#### 5.1.1 Power Specification

Input power specifications are as follows:

Symbol	Parameter	Min	Typ	Max	Unit	Conditions
VDD	Logic/LCD Drive Voltage	4.5	5.0	5.5	[Volt]	+/-10%
IDD	Input Current	-	0.9	1.1	[A]	VDD= 5.0V, All Black Pattern At 60Hz,
PDD	VDD Power	-	4.5	5.5	[Watt]	VDD= 5.0V, All Black Pattern At 60Hz
IRush	Inrush Current	-	-	3	[A]	Note 1
VDDrp	Allowable Logic/LCD Drive Ripple Voltage	-	-	200	[mV] p-p	VDD= 5.0V, All Black Pattern At 60Hz

**Note 1:** Measurement conditions:

The duration of rising time of power input is 470us.

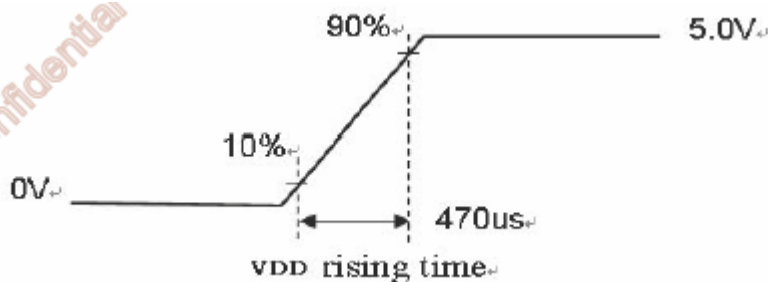
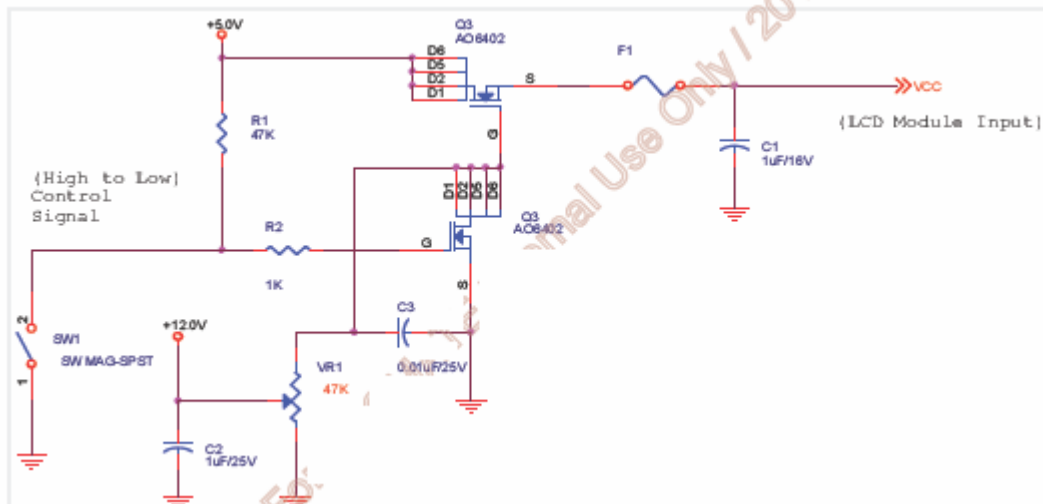

## 5.1.2 Signal Electrical Characteristics

Input signals shall be low or Hi-Z state when VDD is off. Please refer to specifications of SN75LVDS82DGG (Texas Instruments) in detail.

Characteristics of each signal are as follows:

Symbol	Parameter	Min	Typ	Max	Units	Condition
VTH	Differential Input High Threshold	-	+50	+100	[mV]	VICM = 1.2V <b>Note 1</b>
VTL	Differential Input Low Threshold	-100	-50	-	[mV]	VICM = 1.2V <b>Note 1</b>
VID	Input Differential Voltage	100	400	600	[mV]	<b>Note 1</b>
VICM	Differential Input Common Mode Voltage	+1.0	+1.2	+1.4	[V]	VTH-VTL = 200MV (max) <b>Note 1</b>

**Note 1:** LVDS Signal Waveform

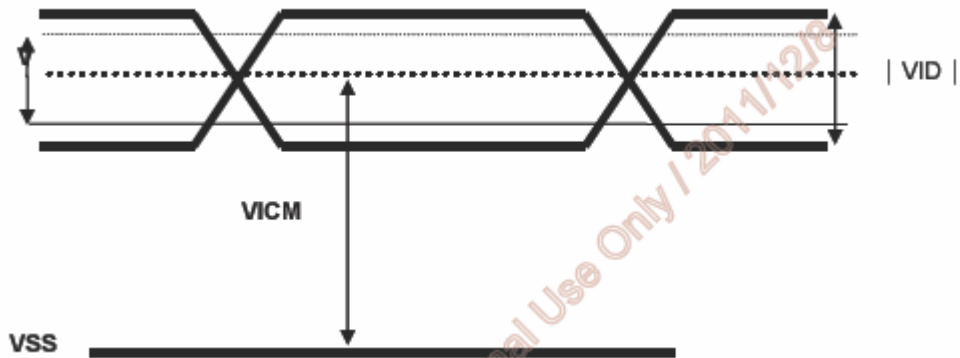



### 5.2 Backlight Unit

Following characteristics are measured under a stable condition at 25 °C (Room Temperature):

Symbol	Parameter	Min.	Typ.	Max.	Unit	Remark
VCC	Input Voltage	10.8	12	13.2	[Volt]	
I <sub>VCC</sub>	Input Current		0.9	1.1	[A]	100% PWM Duty
P <sub>VCC</sub>	Power Consumption		10.8	13.2	[Watt]	100% PWM Duty
I <sub>rush LED</sub>	Inrush Current	-		3	[A]	at rising time=470us
F <sub>PWM</sub>	Dimming Frequency	200	-	20k	[Hz]	
	Swing Voltage	3	3.3	5	V	
	Dimming Duty Cycle	5	-	100	%	
I <sub>F</sub>	LED Forward Current		80		mA	Ta = 25 °C
V <sub>F</sub>	LED Forward Voltage	-	3.2	3.6	Volt	I <sub>F</sub> =mA, Ta = 25 °C
P <sub>LED</sub>	LED Power Consumption	-		10.08	Watt	I <sub>F</sub> =mA, Ta = 25 °C
Operation Lifetime		50,000			Hrs	I <sub>F</sub> =mA, Ta= 25 °C

Note 1: Ta means ambient temperature of TFT-LCD module.

Note 2: VCC, I<sub>VCC</sub>, P<sub>VCC</sub>, I<sub>rush LED</sub> are defined for LED B/L.(100% duty of PWM dimming)

Note 3: I<sub>F</sub>, V<sub>F</sub>, P<sub>LED</sub> are defined for LED Light Bar.

Note 4: If G185XW01 V1 module is driven by high current or at high ambient temperature & humidity condition. The operating life will be reduced.

Note 5: Operation life means brightness goes down to 50% initial brightness. Minimum operating life time is estimated data.



**6.2 The input data format**

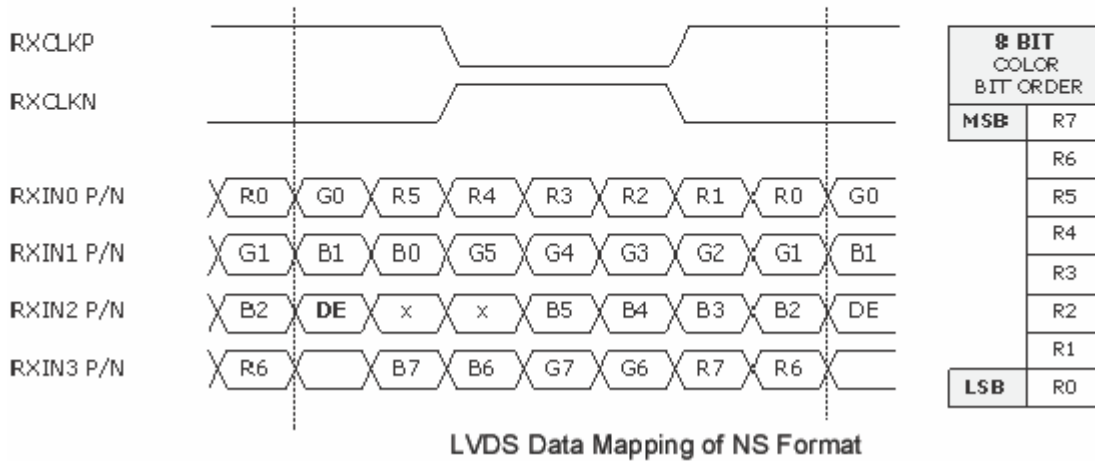

**Note1:** Normally, DE, VS, HS on EVEN channel are not used.  
**Note2:** 8-bits signal input.



### 6.3 Signal Description

The module using one LVDS receiver SN75LVDS82(Texas Instruments). LVDS is a differential signal technology for LCD interface and high speed data transfer device. LVDS transmitters shall be SN75LVDS83(negative edge sampling). The first LVDS port(RxOxxx) transmits odd pixels while the second LVDS port(RxExxx) transmits even pixels.

PIN #	SIGNAL NAME	DESCRIPTION
1~3	NC	No contact (for AUO internal use)
4	GND	Power ground
5	RXIN0-	Negative LVDS Differential data input (0)
6	RXIN0+	Positive LVDS Differential data input (0)
7	GND	Power ground
8	RXIN1-	Negative LVDS Differential data input (1)
9	RXIN1+	Positive LVDS Differential data input (1)
10	GND	Power ground
11	RXIN2-	Negative LVDS Differential data input (2)
12	RXIN2+	Positive LVDS Differential data input (2)
13	GND	Power ground
14	RXCLKIN-	Negative LVDS Differential clock input (clock)
15	RXCLKIN+	Positive LVDS Differential clock input (clock)
16	GND	Power ground
17	RXIN3-	Negative LVDS Differential data input (3)
18	RXIN3+	Positive LVDS Differential data input (3)
19	GND	Power ground
20~22	NC	No contact (for AUO internal use)
23~25	GND	Power ground
26~30	VCC	+5V Power supply

Note1: Start from left side

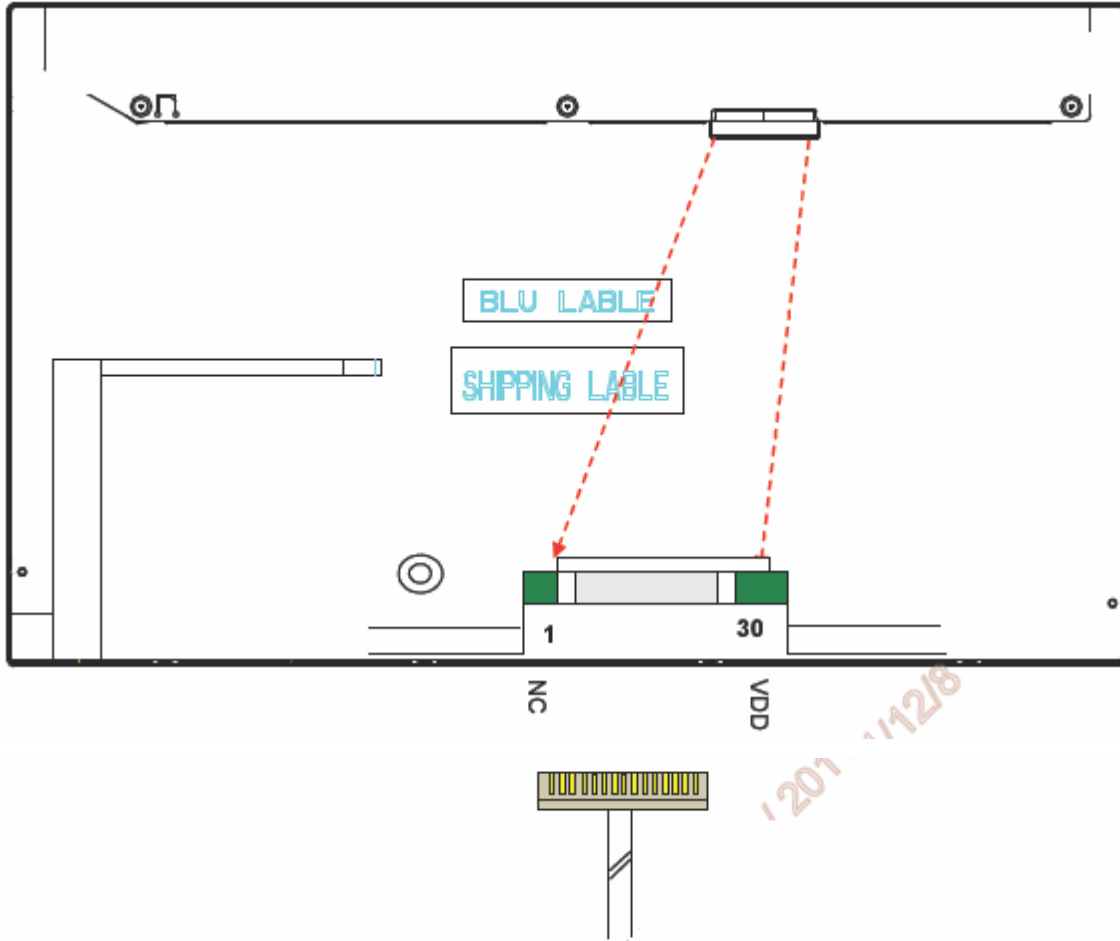

Note2: Input signals of clock shall be the same timing.

Note3: Please follow TV VESA Pin Assignment.

### 6.4 Timing Characteristics

Basically, interface timing described here is not actual input timing of LCD module but close to output timing of SN75LVDS82DGG (Texas Instruments) or equivalent.

Signal	Item	Symbol	Min	Typ	Max	Unit
V-section	Period	Tv	776	808	1023	Th
	Active	Tdisp(v)	768	768	768	Th
	Blanking	Tblk(v)	8	40	255	Th
H-section	Period	Th	1416	1606	2047	Tclk
	Active	Tdisp(h)	1366	1366	1366	Tclk
	Blanking	Tblk(h)	50	240	681	Tclk
Clock	Period	Tclk	-	12.8	-	ns
	Frequency	Freq	-	78	90	MHz
Frame Rate	Frame Rate	F	50	60	75	Hz

Note1 : DE mode only

Note2 : Clock Frequency 90MHz(Max.)= 1416(H)\*847(V)\*75Hz

1/12/8

**6.5 Timing diagram**

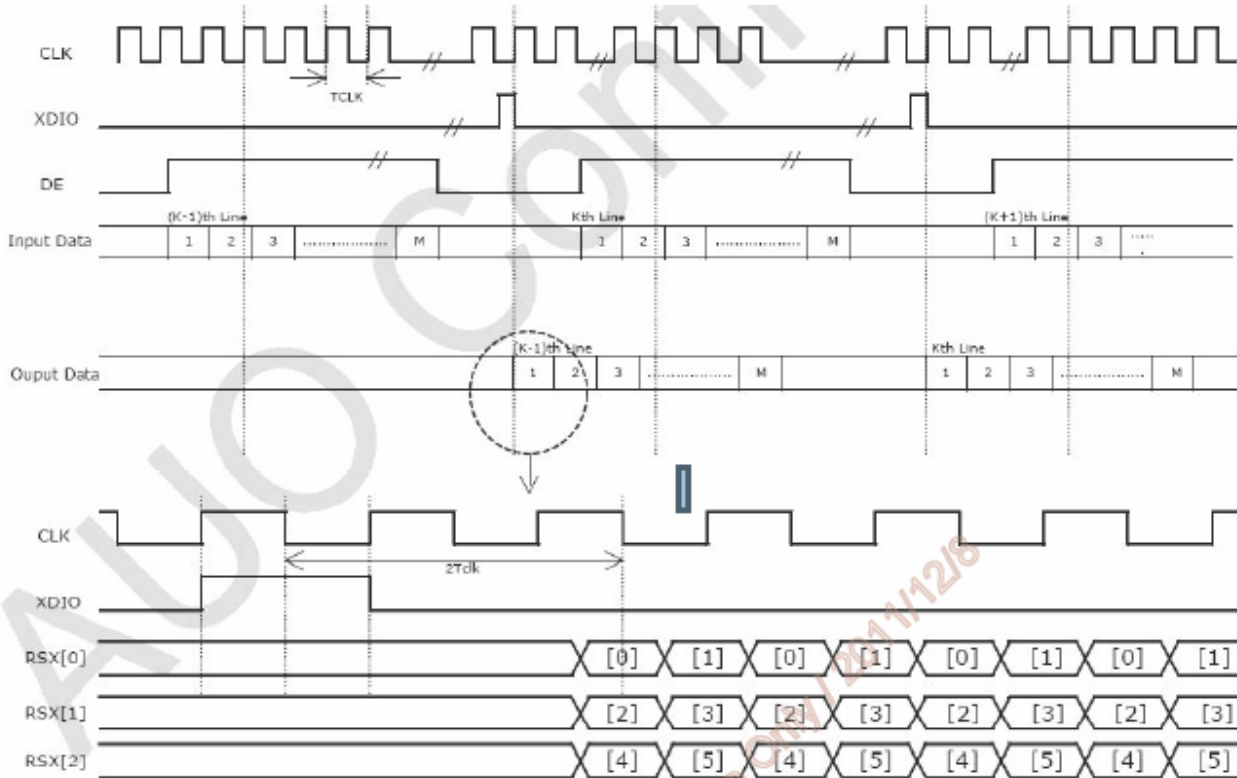

## 6.6 Power ON/OFF Sequence

VDD power and LED on/off sequence are as follows. Interface signals are also shown in the chart. Signals from any system shall be Hi-Z state or low level when VDD is off.

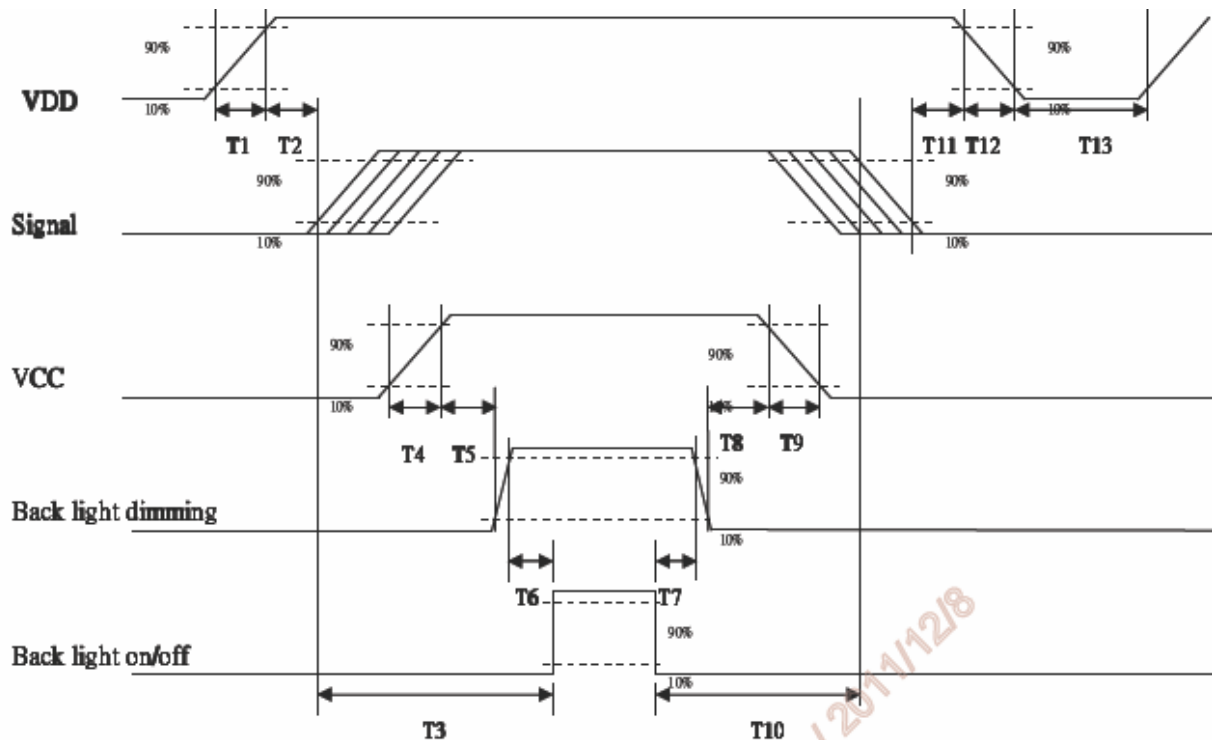

Power ON/OFF sequence timing

Parameter	Value			Units
	Min.	Typ.	Max.	
T1	0.5	-	10	[ms]
T2	0	40	50	[ms]
T3	200	-	-	[ms]
T4	0.5	-	10	[ms]
T5	10	-	-	[ms]
T6	10	-	-	[ms]
T7	0	-	-	[ms]
T8	10	-	-	[ms]
T9	-	-	10	[ms]
T10	110	-	-	[ms]
T11	0.5	16	50	[ms]
T12	-	-	100	[ms]
T13	1000	-	-	[ms]



### 7.0 Connector & Pin Assignment

Physical interface is described as for the connector on module. These connectors are capable of accommodating the following signals and will be following components.

#### 7.1 TFT LCD Module

<b>Connector Name / Designation</b>	<b>Interface Connector / Interface card</b>
Manufacturer	JAE or CHIEF LAND
Type Part Number	FI-XB30SRL-HF11(JAE) / 093F30-B0T01A(CHIEF LAND)
Mating Housing Part Number	FI-X30HL(JAE) (Locked Type) FI-X30H (JAE)(Unlocked Type)

#### 7.1.1 Pin Assignment

Pin#	Signal Name	Pin#	Signal Name
1	NC	2	NC
3	NC	4	GND
5	RXIN0-	6	RXIN0+
7	GND	8	RXIN1-
9	RXIN1+	10	GND
11	RXIN2-	12	RXIN2+
13	GND	14	RXCLKIN-
15	RXCLKIN+	16	GND
17	RXIN3-	18	RXIN3+
19	GND	20	NC
21	NC	22	NC
23	GND	24	GND
25	GND	26	VDD
27	VDD	28	VDD
29	VDD	30	VDD

#### 7.2 LED Backlight Unit: LED Driver Connector

<b>Connector Name / Designation</b>	<b>LED Connector</b>
Manufacturer	E&T or compatible
Connector Model Number	3808K-F05N-02R or compatible
Mating Connector Model Number	H208K-P05N-02B or compatible



**7.3 LED Driver Connector Pin Assignment**

<b>Pin#</b>	<b>Symbol</b>	<b>Signal Name</b>
1	VCC	12V
2	GND	GND
3	Enable	5V-On / 0V-Off
4	Dimming	PWM Dimming
5	NC	NC

## 8.0 Reliability Test

Environment test conditions are listed as following table.

Items	Required Condition	Note
Temperature Humidity Bias (THB)	Ta= 50°C, 80%RH, 300hours	
High Temperature Operation (HTO)	Ta= 60°C, 50%RH, 300hours	
Low Temperature Operation (LTO)	Ta= 0°C, 300hours	
High Temperature Storage (HTS)	Ta= 60°C, 300hours	
Low Temperature Storage (LTS)	Ta= -20°C, 300hours	
Vibration Test (Non-operation)	Acceleration: 1.5 Grms Wave: Random Frequency: 10 - 200 Hz Sweep: 30 Minutes each Axis (X, Y, Z)	
Shock Test (Non-operation)	Acceleration: 50 G Wave: Half-sine Active Time: 20 ms Direction: ±X, ±Y, ±Z (one time for each Axis)	
Drop Test	Height: 60 cm, package test	
Thermal Shock Test (TST)	-20°C /30min, 60°C /30min, 100 cycles	<b>1</b>
On/Off Test	On/10sec, Off/10sec, 30,000 cycles	
ESD (Electro Static Discharge)	Contact Discharge: ± 8KV, 150pF(330Ω ) 1sec, 8 points, 25 times/ point	<b>2</b>
	Air Discharge: ± 15KV, 150pF(330Ω ) 1sec 8 points, 25 times/ point	

**Note 1:** The TFT-LCD module will not sustain damage after being subjected to 100 cycles of rapid temperature change. A cycle of rapid temperature change consists of varying the temperature from -20°C to 60°C, and back again. Power is not applied during the test. After temperature cycling, the unit is placed in normal room ambient for at least 4 hours before power on.

**Note 2:** According to EN61000-4-2 , ESD class B: Some performance degradation allowed. No data lost. Self-recoverable. No hardware failures.

### 9.0 Shipping Label & Packaging

#### 9.1 Shipping Label

The label is on the panel as shown below:



*Note 1:* For Pb Free products, AUO will add  for identification.

*Note 2:* For RoHS compatible products, AUO will add  for identification.

*Note 3:* For China RoHS compatible products, AUO will add  for identification.

*Note 4:* The Green Mark will be presented only when the green documents have been ready by AUO Internal Green Team.

11/12/0

### 9.2 Packaging

Carton Outline : L\*W\*H : 519\*279\*332 mm  
Panel per Carton: 8 pcs  
Carton per Pallet: 24 pcs

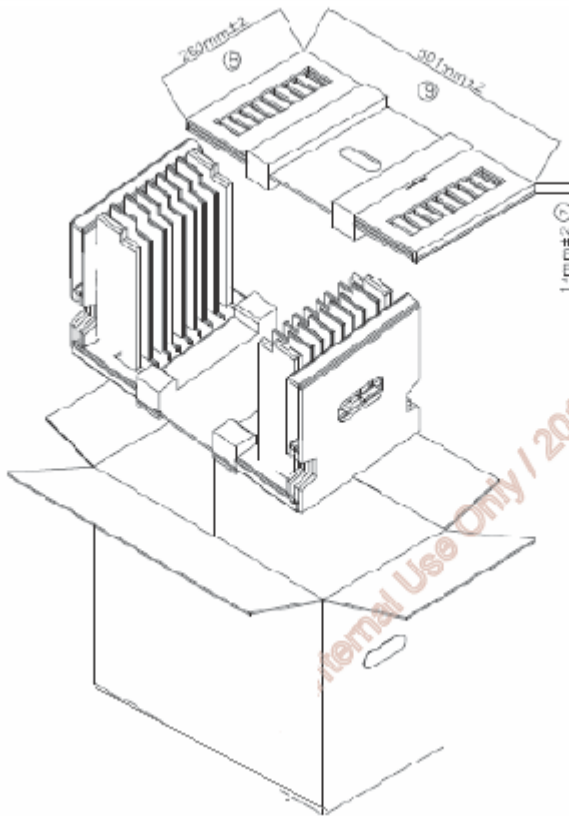

## 10.0 Mechanical Characteristics

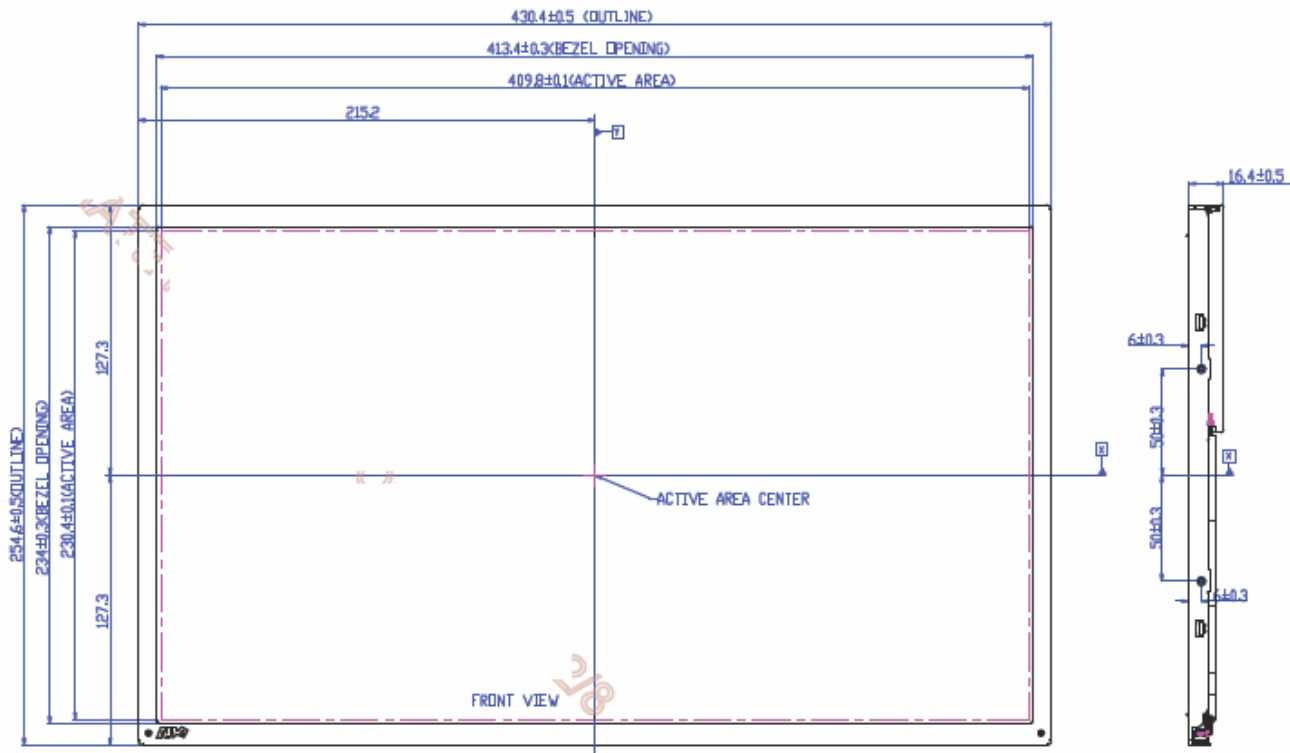

### NOTES:

1. BACKLIGHT: 2 COLD CATHODE FLUORESCENT LAMPS.
2. I/F CONNECTOR.
3. TOLERANCE WITHOUT SPECIFIED TO BE 0.5 mm.
4. LAMP CABLE CONNECTOR TO BE YEON HO 35001HS-02L.
5. THIS DIMENSION EXCLUDES DEFORMATION.
6. TORQUE OF M3 USER HOLE SHOULD BE WITHIN 3 KGF-CM AND RE-SCREW 10 TIMES.

