

PREPARED BY : DATE	<h1>SHARP</h1> <p>MOBILE LIQUID CRYSTAL DISPLAY GROUP SHARP CORPORATION</p> <h2>SPECIFICATION</h2>	SPEC No. LD-17504B
APPROVED BY : DATE		FILE No.
		ISSUE : MAY. 19. 2005
		PAGE : 19 pages
		APPLICABLE GROUP
		MOBILE LIQUID CRYSTAL DISPLAY GROUP

REV. JUN. 11. 2007

DEVICE SPECIFICATION FOR
TFT-LCD Module
 MODEL No.
LQ121S1LG44

These parts have corresponded with the RoHS directive.

CUSTOMER'S APPROVAL

BY _____

BY  _____

A. Yamaguchi
 General manager
 ENGINEERING DEPARTMENT I
 MOBILE LIQUID CRYSTAL DISPLAY DIVISION III
 MOBILE LIQUID CRYSTAL DISPLAY GROUP
 SHARP CORPORATION

1. Application

This specification applies to color TFT-LCD module, LQ121S1LG44

These specification sheets are the proprietary product of SHARP CORPORATION("SHARP) and include materials protected under copyright of SHARP. Do not reproduce or cause any third party to reproduce them in any form or by any means, electronic or mechanical, for any purpose, in whole or in part, without the express written permission of SHARP.

The device listed in these specification sheets was designed and manufactured for use in general electronic equipment.

In case of using the device for applications such as control and safety equipment for transportation (aircraft, trains, automobiles, etc.), rescue and security equipment and various safety related equipment which require higher reliability and safety, take into consideration that appropriate measures such as fail-safe functions and redundant system design should be taken.

Do not use the device for equipment that requires an extreme level of reliability, such as aerospace applications, telecommunication equipment (trunk lines), nuclear power control equipment and medical or other equipment for life support.

SHARP assumes no responsibility for any damage resulting from the use of the device which does not comply with the instructions and the precautions specified in these specification sheets.

Confirm "12. Handling Precautions " item when you use the device.

Contact and consult with a SHARP sales representative for any questions about this device.

2. Overview

This module is a color active matrix LCD module incorporating amorphous silicon TFT (Thin Film Transistor). It is composed of a color TFT-LCD panel, driver ICs, control circuit and power supply circuit and a backlight unit. Graphics and texts can be displayed on a 800 X 3 X 600 dots panel with 262,144 colors by using LVDS (Low Voltage Differential Signaling) system for interface and supplying +3.3V +5.0V DC supply voltage for TFT-LCD panel driving and supply voltage for backlight.

The TFT-LCD panel used for this module is a low-reflection and higher-color-saturation type.

Therefore, this module is also suitable for the multimedia use. Viewing angle is 6 o'clock direction.

This module is the type of wide viewing angle and high brightness(370cd/m2).

Backlight-driving DC/AC inverter is not built in this module.

3. Outline Specifications

Parameter	Specifications	Unit
Display size	31 (12.1") Diagonal	cm
Active area	246.0 (H) X 184.5 (V)	mm
Pixel format	800 (H) X 600 (V)	pixel
	(1 pixel=R+G+B dots)	
Number of colors (Number of gray scale level)	262, 144 colors (64 gray scales per color)	
Pixel pitch	0.3075 (H) X 0.3075 (V)	mm
Pixel configuration	R,G,B vertical stripe	
Display mode	Normally white	
Unit outline dimensions *1	276.0(W)×209.0(H)×Max.11.0 (D) *Outline dimensions is shown in Fig.1	mm
Mass	MAX. 660	g
Surface treatment	Anti-glare and hard-coating 3H	

[Note] excluding backlight cables.

4. Input Terminals

4-1. TFT-LCD panel driving

CN1 (LVDS signals , +3.3V / +5.0V DC power supply and Control signal)

Corresponding connector:FI-SE20M (JAE) or FI-S20S (JAE)

Pin No.	Symbol	Function	Remark
1	V _{CC}	+3.3V / +5.0V power supply	
2	V _{CC}	+3.3V / +5.0V power supply	
3	GND		
4	GND		
5	RXIN0-	Differential data input, CH0 (negative)	LVDS signal
6	RXIN0+	Differential data input, CH0 (positive)	LVDS signal
7	GND		
8	RXIN1-	Differential data input, CH1 (negative)	LVDS signal
9	RXIN1+	Differential data input, CH1 (positive)	LVDS signal
10	GND		
11	RXIN2-	Differential data input, CH2 (negative)	LVDS signal
12	RXIN2+	Differential data input, CH2 (positive)	LVDS signal
13	GND		
14	RXCLK IN-	Differential clock input (negative)	LVDS signal
15	RXCLK IN+	Differential clock input (positive)	LVDS signal
16	GND		
17	R/L	Horizontal display mode select signal	[Note1]
18	U/D	Vertical display mode select signal	[Note2]
19	GND		
20	GND		

[Note] To obtain the proper relation between LVDS signals and actual digital data signals, the digital signals should be inputted into the transmitter as described in the nextsection, 4-2. The shielding case is connected with signal GND.

[Note 1],[Note 2]

R/L = High, U/D = Low

R/L = Low, U/D = Low



R/L = High, U/D = High



R/L = Low, U/D = High



4-2 Data Mapping

1) 6 bit input

【note1】 pin assignment (Thine:THC63LVDF64A)

Transmitter		Symbol
Pin No	Data	
51	TA0	R0 (LSB)
52	TA1	R1
54	TA2	R2
55	TA3	R3
56	TA4	R4
3	TA5	R5 (MSB)
4	TA6	G0 (LSB)
6	TB0	G1
7	TB1	G2
11	TB2	G3
12	TB3	G4
14	TB4	G5 (MSB)
15	TB5	B0 (LSB)
19	TB6	B1
20	TC0	B2
22	TC1	B3
23	TC2	B4
24	TC3	B5 (MSB)
27	TC4	HS
28	TC5	VS
30	TC6	DE

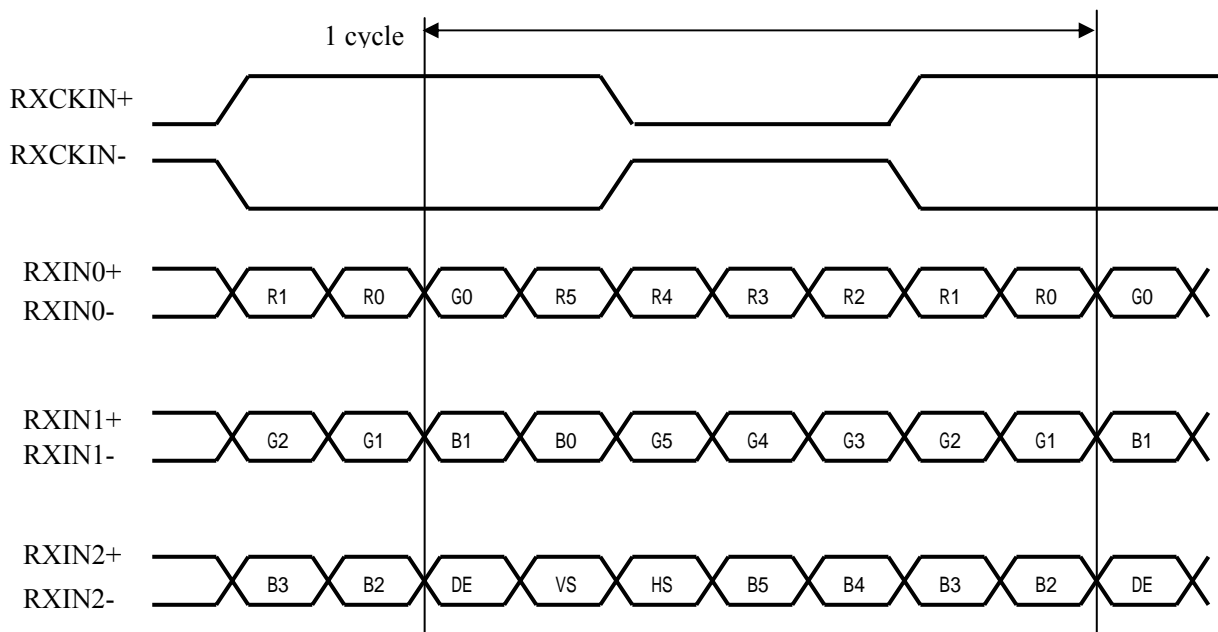

DE : Display Enable

4-2 LVDS Interface block diagram

Using receiver : Single LVDS interface, which equals THC63LVDF64A(THine),contained in a control IC

Corresponding Transmitter : DS90C363, DS90C363A, DS90C383, DS90C383A(National semiconductor),

THC63LVDF63A,THC63LVDM63A(THine), SN75LVDS84(Ti)

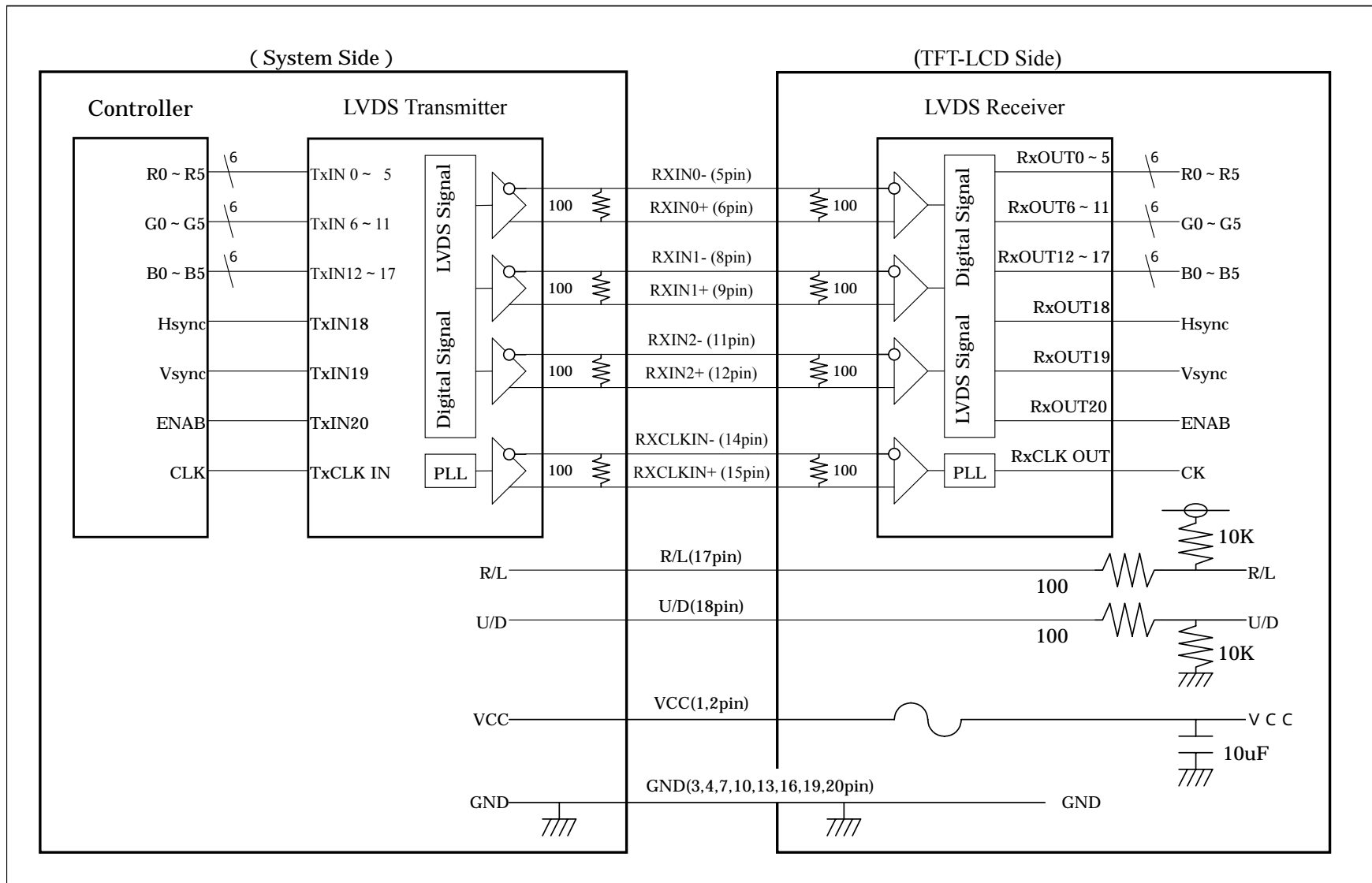

7. Electrical Characteristics

7-1. TFT-LCD panel driving

Ta=25 °C

Parameter		Symbol	Min.	Typ.	Max.	Unit	Remark
Current dissipation	Vcc=+3.3V	Icc	-	380	480	mA	[Note1]
	Vcc=+5.0V	Icc	-	230	280	mA	
Permissive input ripple voltage		VRP	-	-	100	mVp-p	
Input voltage range	LVDS signal	VL	0	-	2.4	V	[Note2]
Differential input threshold voltage	High	VTH	-	-	VCM+ 100	mV	V _{CM} =1.2V [Note3]
	Low	VTL	VCM- 100	-	-	mV	
Input impedance (Differential input)		RT	-	100	-		[Note2]
Input voltage	Low	VIL	-	-	0.8	V	[Note4]
	High	VIH	2.1	-	-		[Note5]
Input current1	Low(VI=0V)	IOL1	-800	-	-		[Note4]
	High(VI=Vcc)	IOH1	-10.0	-	10.0		
Input current2	Low(VI=0V)	IOL2	-10.0	-	10.0	uA	[Note5]
	High(VI=Vcc)	IOH2	-	-	800	uA	

[Note1] Typical current situation : 16-gray-bar pattern.

Vcc=+3.3V / +5.0V

[Note2] LVDS signals

[Note3] V_{CM} : Common mode voltage of LVDS driver.

[Note4] R/L

[Note5] U/D

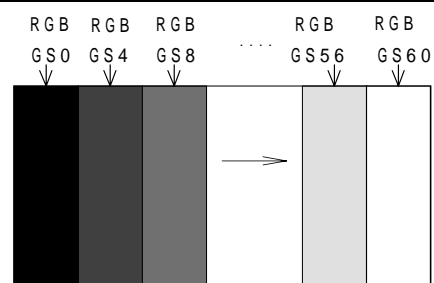

7-2. Backlight driving

The backlight system is an edge-lighting type with single CCFT (Cold Cathode Fluorescent Tube).

The characteristics of single lamp are shown in the following table.

Parameter	Symbol	Min.	Typ.	Max.	Unit	Remark
Lamp current range	IL	3.0	6.0	7.0	mArms	[Note1]
Lamp power consumption	PL	-	3.5	-	W	[Note2]
Lamp frequency	FL	40	60	80	kHz	[Note3]
Kick-off voltage	Vs	-	-	1400	Vrms	Ta=0 °C
		-	-	1500		Ta=-10 °C
Lamp life time	LL	50000	-	-	hour	[Note5]

[Note1] Lamp current is measured with current meter for high frequency as shown below.

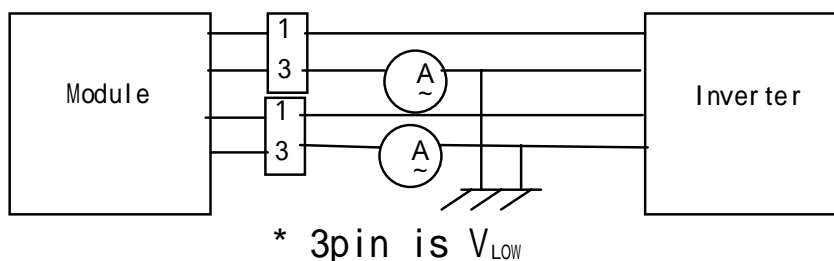

[Note2] At the condition of

IL=6.0mArms

[Note3] Lamp frequency may produce interference with horizontal synchronous frequency, and this may cause beat on the display. Therefore lamp frequency shall be detached as much as possible from the horizontal synchronous frequency and from the harmonics of horizontal synchronous to avoid interference.

[Note4] The voltage above this value should be applied to the lamp for more than 1 second to start-up. Otherwise the lamp may not be turned on.

[Note5] Since lamp is consumables, the life time written above is referencial value and it is not guaranteed in this specification sheet by SHARP.

Since lamp is consumables, the life time written above is referencial value and it is not guaranteed in this specification sheet by SHARP.

Lamp life time is defined that it applied either or under this condition
(Continuous turning on at Ta=25 °C, IL=6.0mArms)

Brightness becomes 50% of the original value under standard condition.

Kick-off voltage at Ta=-10 °C exceeds maximum value, 1500Vrms.

In case of operating under lower temp environment, the lamp exhaustion is accelerated and the brightness becomes lower. (Continuous operating under for around 1 month under lower temp condition may reduce the brightness to half of the original brightness.)

In case of operating under lower temp environment, the lamp exhaustion is accelerated and the brightness becomes lower. (Continuous operating for around 1 month under lower temp condition may reduce the brightness to half of the original brightness.)

The life of a lamp is accelerated when using it in the environment where a lamp cannot get warm easily.
(When using it outdoors and ON/OFF is repeated frequently)

In case of such usage under lower temp environment, periodical lamp check and exchange is recommended.

[Note6] The performance of the backlight, for example life time or brightness, is much influenced by the characteristics of the DC-AC inverter for the lamp. When you design or order the inverter, please make sure that a poor lighting caused by the mismatch of the backlight and the inverter (miss-lighting, flicker, etc.) never occur. When you confirm it, the module should be operated in the same condition as it is installed in your instrument.

Be sure to use a back light power supply with the safety protection circuit such as the detection circuit for the excess voltage, excess current and or electric discharge waveform.

Be sure to use the detect circuit by which one side of the CCFT lamps can be controlled independently. Otherwise, when one side of the CCFT is open, the excess current may possibly be applied to the other side of the lamp.

(lamp lifetime may vary if lamp is in portrait position due to the change of mercury density inside the lamp.). Recommended inverter is "CXA-P1212B-WJL(TDK corporation)".

[Note7] It is required to have the inverter designed so that to allow the impedance deviation of the two CCFT lamps and the capacity deviation of barast capacitor.

[Note8] Under the environment of 10lx or less, miss-lighting delay may occur.

[Note9] Insulate the high voltage area in order to prevent direct contacts to the area. As countermeasures for excessive heat or exothermic fire, use protection elements such as fuses to cut the circuit. Use burn-resistant (or noncombustible) material for board or resin.

8. Timing characteristics of input signals

8-1. Timing characteristics

(These are specified at the digital inputs/outputs of LVDS transmitter/receiver.)

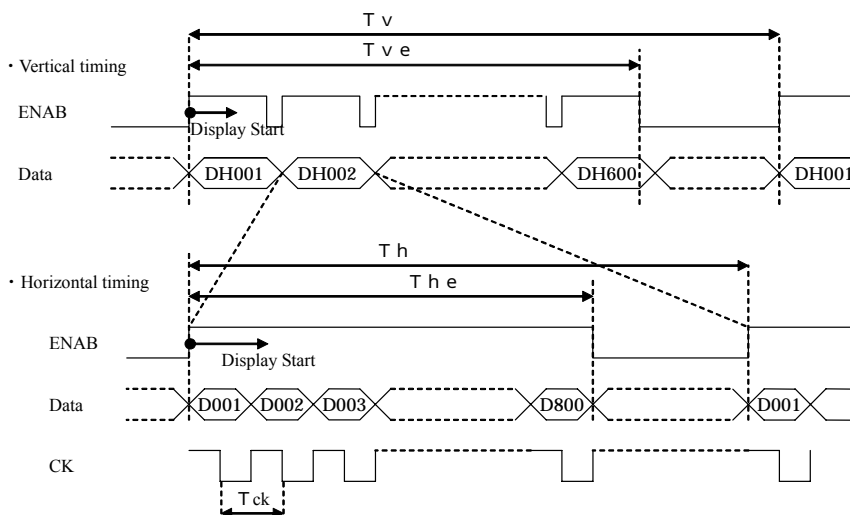

(Vertical timing)

Item(symbol)	Min.	Typ.	Max.	Unit	Remark
Vsync cycle (T_v)	-	17.6	-	ms	Negative
	628	666	798	line	
Active display area (T_{ve})	600	600	600	line	

(Horizontal timing)

Item(symbol)	Min.	Typ.	Max.	Unit	Remark
Hsync cycle (T_h)	20.8	26.4	39.9	us	Negative
	832	1056	1395	clock	
Active display area (T_{he})	800	800	800	clock	

(Clock signal)

Item	Min.	Typ.	Max.	Unit	Remark
Frequency ($1/T_{ck}$)	35	40	42	MHz	[Note1]

[Note1] In case of lower frequency, the deterioration of display quality, flicker etc., may be occurred.

8-2. Input Data Signals and Display Position on the screen

Display position of input data
(H, V)

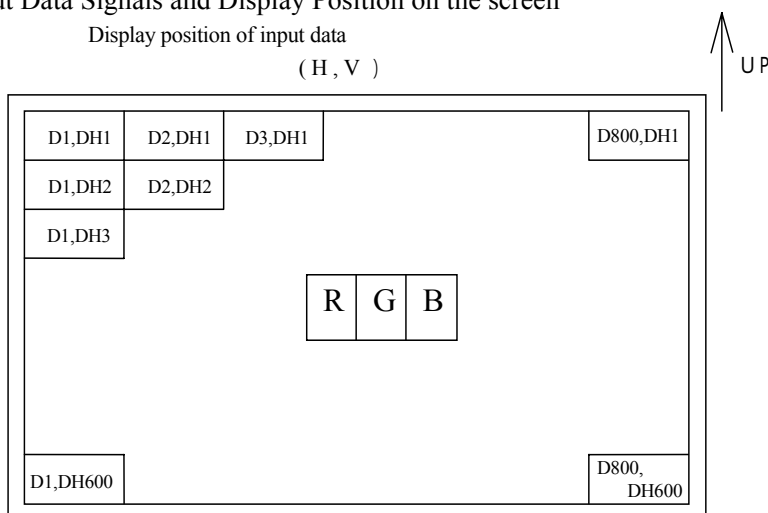

9. Input Signals, Basic Display Colors and Gray Scale of Each Color

Colors & Gray scale	Data signal																			
	Gray Scale	R0	R1	R2	R3	R4	R5	G0	G1	G2	G3	G4	G5	B0	B1	B2	B3	B4	B5	
Basic Color	Black	-	0	0	0	0	0	0	0	0	0	0	0	0	0	0	0	0	0	
	Blue	-	0	0	0	0	0	0	0	0	0	0	0	1	1	1	1	1	1	
	Green	-	0	0	0	0	0	0	1	1	1	1	1	1	0	0	0	0	0	
	Cyan	-	0	0	0	0	0	0	1	1	1	1	1	1	1	1	1	1	1	
	Red	-	1	1	1	1	1	1	0	0	0	0	0	0	0	0	0	0	0	
	Magenta	-	1	1	1	1	1	1	0	0	0	0	0	0	1	1	1	1	1	
	Yellow	-	1	1	1	1	1	1	1	1	1	1	1	1	0	0	0	0	0	
	White	-	1	1	1	1	1	1	1	1	1	1	1	1	1	1	1	1	1	
Gray Scale of Red	Black	GS0	0	0	0	0	0	0	0	0	0	0	0	0	0	0	0	0	0	
	↑	GS1	1	0	0	0	0	0	0	0	0	0	0	0	0	0	0	0	0	
	Darker	GS2	0	1	0	0	0	0	0	0	0	0	0	0	0	0	0	0	0	
	↑	↓				↓				↓							↓			
	↓	↓				↓				↓							↓			
	Brighter	GS61	1	0	1	1	1	1	0	0	0	0	0	0	0	0	0	0	0	
	↓	GS62	0	1	1	1	1	1	0	0	0	0	0	0	0	0	0	0	0	
	Red	GS63	1	1	1	1	1	1	0	0	0	0	0	0	0	0	0	0	0	
Gray Scale of Green	Black	GS0	0	0	0	0	0	0	0	0	0	0	0	0	0	0	0	0	0	
	↑	GS1	0	0	0	0	0	0	1	0	0	0	0	0	0	0	0	0	0	
	Darker	GS2	0	0	0	0	0	0	0	1	0	0	0	0	0	0	0	0	0	
	↑	↓				↓				↓							↓			
	↓	↓				↓				↓							↓			
	Brighter	GS61	0	0	0	0	0	0	1	0	1	1	1	1	0	0	0	0	0	
	↓	GS62	0	0	0	0	0	0	0	1	1	1	1	1	0	0	0	0	0	
	Green	GS63	0	0	0	0	0	0	1	1	1	1	1	1	0	0	0	0	0	
Gray Scale of Blue	Black	GS0	0	0	0	0	0	0	0	0	0	0	0	0	0	0	0	0	0	
	↑	GS1	0	0	0	0	0	0	0	0	0	0	0	1	0	0	0	0	0	
	Darker	GS2	0	0	0	0	0	0	0	0	0	0	0	0	1	0	0	0	0	
	↑	↓				↓				↓							↓			
	↓	↓				↓				↓							↓			
	Brighter	GS61	0	0	0	0	0	0	0	0	0	0	0	0	1	0	1	1	1	1
	↓	GS62	0	0	0	0	0	0	0	0	0	0	0	0	0	1	1	1	1	1
	Blue	GS63	0	0	0	0	0	0	0	0	0	0	0	0	1	1	1	1	1	1

0 :Low level voltage, 1 : High level voltage

Each basic color can be displayed in 64 gray scales from 6 bit data signals. According to the combination of total 18 bit data signals, the 262,144-color display can be achieved on the screen.

10. Optical Characteristics

Ta=25°C, Vcc=+3.3V / +5.0V

Parameter		Symbol	Condition	Min.	Typ.	Max.	Unit	Remark	
Viewing angle range	Horizontal	21, 22	CR>10	60	70	-	Deg.	[Note1]	
	Vertical	11		35	50	-	Deg.	[Note4]	
		12		55	60	-	Deg.		
Contrast ratio		CRn	=0°	150	-	-	-	[Note2]	
		CRo	Optimum viewing angle	-	450	-	-	[Note4]	
Response time	Rise	r	=0°	-	15	-	ms	[Note3]	
	Decay	d		-	30	-	ms	[Note4]	
Chromaticity of white		x	=0°	0.283	0.313	0.343	-	[Note4]	
		y		0.299	0.329	0.359	-		
Chromaticity of red		x		0.566	0.596	0.626	-		
		y		0.299	0.329	0.359	-		
Chromaticity of green		x		0.280	0.310	0.340	-		
		y		0.522	0.552	0.582	-		
Chromaticity of blue		x		0.118	0.148	0.178	-		
		y		0.095	0.125	0.155	-		
Luminance of white		Y _{L1}		300	370	-	cd/m ²		IL=6.0mArms fL=60kHz
White Uniformity		δW		-	-	1.25	-		[Note5]
Viewing angle range within defined brightness	21, 22	50% of the maximum brightness	-	35	-	Deg.	[Note1]		
	11		-	25	-	Deg.			
	12		-	30	-	Deg.			

[Note]

The measurement shall be executed 30 minutes after lighting at rating.
 The optical characteristics shall be measured in a dark room or equivalent state with the method shown in Fig.3 below.

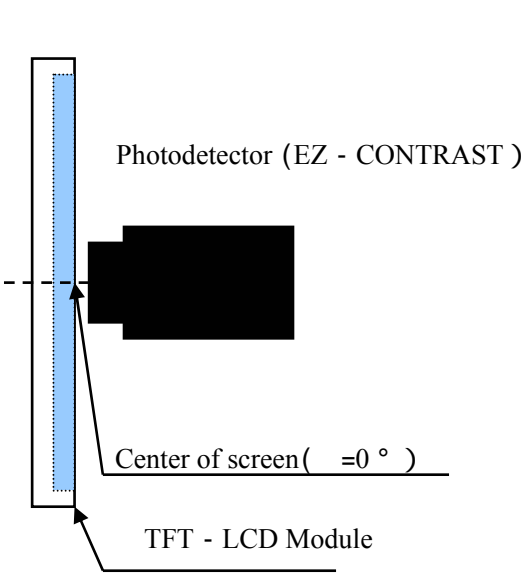

Fig2-1 Viewing angle measurement method

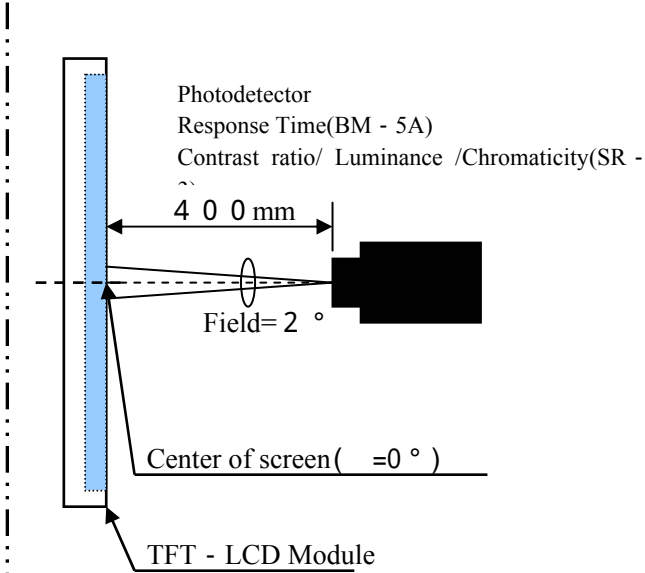
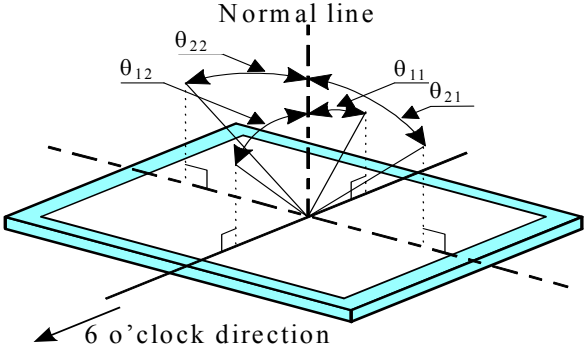

Fig2-2 Luminance/Contrast ratio/Response time/Chromaticity measurement method

Fig2 Optical characteristics measurement method

[Note1]Definitions of viewing angle range:



[Note2]Definition of contrast ratio:

The contrast ratio is defined as the following.

$$\text{Contrast Ratio (CR)} = \frac{\text{Luminance (brightness) with all pixels white}}{\text{Luminance (brightness) with all pixels black}}$$

[Note3]Definition of response time:

The response time is defined as the following figure and shall be measured by switching the input signal for "black" and "white" .

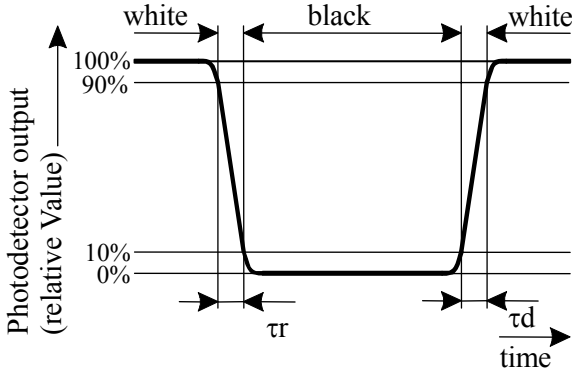

[Note4]This shall be measured at center of the screen.

[Note5]Definition of white uniformity:

White uniformity is defined as the following with five measurements (A~E).

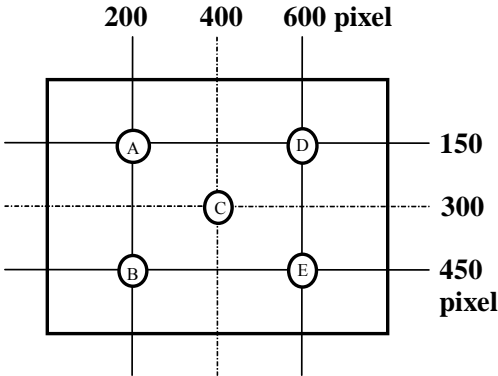

$$w = \frac{\text{Maximum Luminance of five points (brightness)}}{\text{Minimum Luminance of five points (brightness)}}$$

11. Display Quality

The display quality of the color TFT-LCD module shall be in compliance with the Incoming Inspection Standard.

12. Handling Precautions

- a) Be sure to turn off the power supply when inserting or disconnecting the cable.
- b) Be sure to design the cabinet so that the module can be installed without any extra stress such as warp or twist.
- c) Since the front polarizer is easily damaged, pay attention not to scratch it.
Blow away dust on the polarizer with antistatic N₂ blow. It is undesirable to wipe off because a polarizer is sensitive.
It is recommended to peel off softly using the adhesive tape when soil or finger oil is stuck to the polarizer.
When unavoidable, wipe off carefully with a cloth for wiping lenses.
- d) Wipe off water drop immediately. Long contact with water may cause discoloration or spots.
- e) When the panel surface is soiled, wipe it with absorbent cotton or other soft cloth.
- f) Since the panel is made of glass, it may break or crack if dropped or bumped on hard surface. Handle with care.
- g) Since CMOS LSI is used in this module, take care of static electricity and injure the human earth when handling.
Observe all other precautionary requirements in handling components.
- h) Since there is a circuit board in the module back, stress is not added at the time of a design assembly.
Please make it like. If stress is added, there is a possibility that circuit parts may be damaged.
- i) Protection film is attached to the module surface to prevent it from being scratched .
Peel the film off slowly , just before the use, with strict attention to electrostatic charges.
Blow off 'dust' on the polarizer by using an ionized nitrogen.
- j) The polarizer surface on the panel is treated with Anti-Glare for low reflection. In case of attaching protective board over the LCD, be careful about the optical interface fringe etc. which degrades display quality.
- k) Do not expose the LCD panel to direct sunlight. Lightproof shade etc. should be attached when LCD panel is used under such environment
- l) Connect GND to 4 place of mounting holes to stabilize against EMI and external noise.
- m) There are high voltage portions on the backlight. It is very dangerous to touch carelessly.
It may lead to electrical shock. When exchanging lamps or getting service, turn off the power without fail.
- n) When handling LCD modules and assembling them into cabinets, please be noted that long-term storage in the environment of oxidization or deoxidization gas and the use of such materials as reagent, solvent, adhesive, resin, etc. which generate these gasses, may cause corrosion and discoloration of the LCD modules.
- o) Cold cathode fluorescent lamp in LCD panel contains a small amount of mercury, please follow local ordinances or regulations for disposal.
- p) Be careful of a back light lead not to pull by force at the time of the wiring to an inverter, or line processing.
- q) When install LCD modules in the cabinet, please tighten with “torque=0.294 ± 0.02N· m(3.0 ± 0.2kgf· cm)”.
Be sure to confirm it in the same condition as it is installed in your instrument.
- r) Liquid crystal contained in the panel may leak if the LCD is broken. Rinse it as soon as possible if it gets inside your eye or mouth by mistake.
- s) Never dismantle the module , because it will cause failure.
Please don't remove the fixed tape, insulateing tape etc that was pasted on the original module.
(except for protection film of the panel and the crepe tape(yellow tape) of fixing lamp cable temporarily.)
- t) Be careful when using it for long time with fixed pattern display as it may cause afterimage.
(Please use a screen saver etc., in order to avoid an afterimage.)
- u) Adjusting volume have been set optimally before shipment, so do not change any adjusted value.
If adjusted value is changed, the specification may not be satisfied.
- v) If a minute particle enters in the module and adheres to an optical material, it may cause display non-uniformity issue, etc. Therefore, fine-pitch filters have to be installed to cooling and inhalation hole if you intend to install a fan.
- w) The lamp used for this product is very sensitive to the temperature.
Luminance decreases rapidly when it is used for a long time or repeatedly under the environment of the low temperature or the module is being cooled.
Please avoid the continuous or repeating use of it under such an environment.
It may decrease up to 50% of the initial luminance in about one month under the low temperature environment.
Please consult our company when it is used under the environment like the above mentioned.
- x) In case of operating under lower temp environment, the lamp exhaustion is accelerated and the brightness

becomes lower. (Continuous operating for around 1 month under lower temp condition may reduce the brightness

to half of the original brightness.)

The life of a lamp is accelerated when using it in the environment where a lamp cannot get warm easily.

(When using it outdoors and ON/OFF is repeated frequently)

In case of such usage under lower temp environment, periodical lamp check and exchange is recommended.

13. Packing form

Product country	JAPAN	TAIWAN	CHINA
Piling number of cartons	MAX. 5		
Package quantity in one carton	10pcs		
Carton size	395(W)×275(H)×350(D) mm		
Total mass of one carton filled with full modules	8000g		
Packing form is shown	Fig.2		

14. Reliability test items

No.	Test item	Conditions	Remark
1	High temperature storage test	Ta=70 240h	
2	Low temperature storage test	Ta= -30 240h	
3	High temperature & high humidity operation test	Ta=40 ; 95%RH 240h (No condensation)	
4	High temperature operation test	Ta=65 240h	
5	Low temperature operation test	Ta= -10 240h	
6	Vibration test (non- operating)	Frequency: 10 ~ 57Hz/Vibration width (one side):0.075mm : 57 ~ 500Hz/Gravity:9.8m/s ² Sweep time : 11 minutes Test period : 3 hours (1 hour for each direction of X,Y,Z)	
7	Shock test (non- operating)	Max. gravity : 490m/s ² Pulse width : 11ms, half sine wave Direction : ± X, ± Y, ± Z once for each direction.	
8	ESD test	Contact discharge (150pF 330) non-operating = ± 10kV, operating = ± 8kV Atmospheric discharge (150pF 330) non-operating = ± 20kV, operating = ± 15kV	
9	EMI	Measurement in 10m site Display position on the screen = "H" (full-screen), GND to 4 place = un-connect, Vcc / Vsignal = typ.	VCCI (Class B)

[Result Evaluation Criteria]

Under the display quality test conditions with normal operation state, these shall be no change which may affect practical display function. (normal operation state : Temperature:15 ~ 35 , Humidity:45 ~ 75%, Atmospheric pressure:86 ~ 106kpa)

15.Others

1) Lot number Label:

Model number

Lot Number .

* Discernment code

(5) (7) (T) (0) (0) (0) (0) (1) (A)

Product	Thine	EPSON
Japan	A	C
Taiwan	G	L
China	Z	X

Product country	
Japan	MADE IN JAPAN
Taiwan	MADE IN TAIWAN
China	MADE IN CHINA

Serial No (5 digits)

Assembly site code

Production month (1-9X, Y, Z)

Production year (Last digit of dominical year)

15-2 Packing box Label:

Quantity of module : Japan

Quantity of module : Taiwan or China

社内品番 : (4 S) LQ121S1LG44

Barcode

LotNO. : (1 T) 2005 . 07 . 01

Barcode

Quantity : (Q) 10 pcs

Barcode

ユーザ品番 :

シャープ物流用ラベルです。

Model number

Lot number (DATE)

Quantity of module

TYPE	LQ121S1LG44
QUANTITY	10pcs
DATE	2005 07 01

ASIC Vendor		
Product country	Thine	EPSON
Japan		LQ121S1LG44 C
Taiwan		LQ121S1LG44 L
China	LQ121S1LG44 Z	LQ121S1LG44 X

15-3 If any problem occurs in relation to the description of this specification , it shall be resolved through discussion with spirit of cooperation.

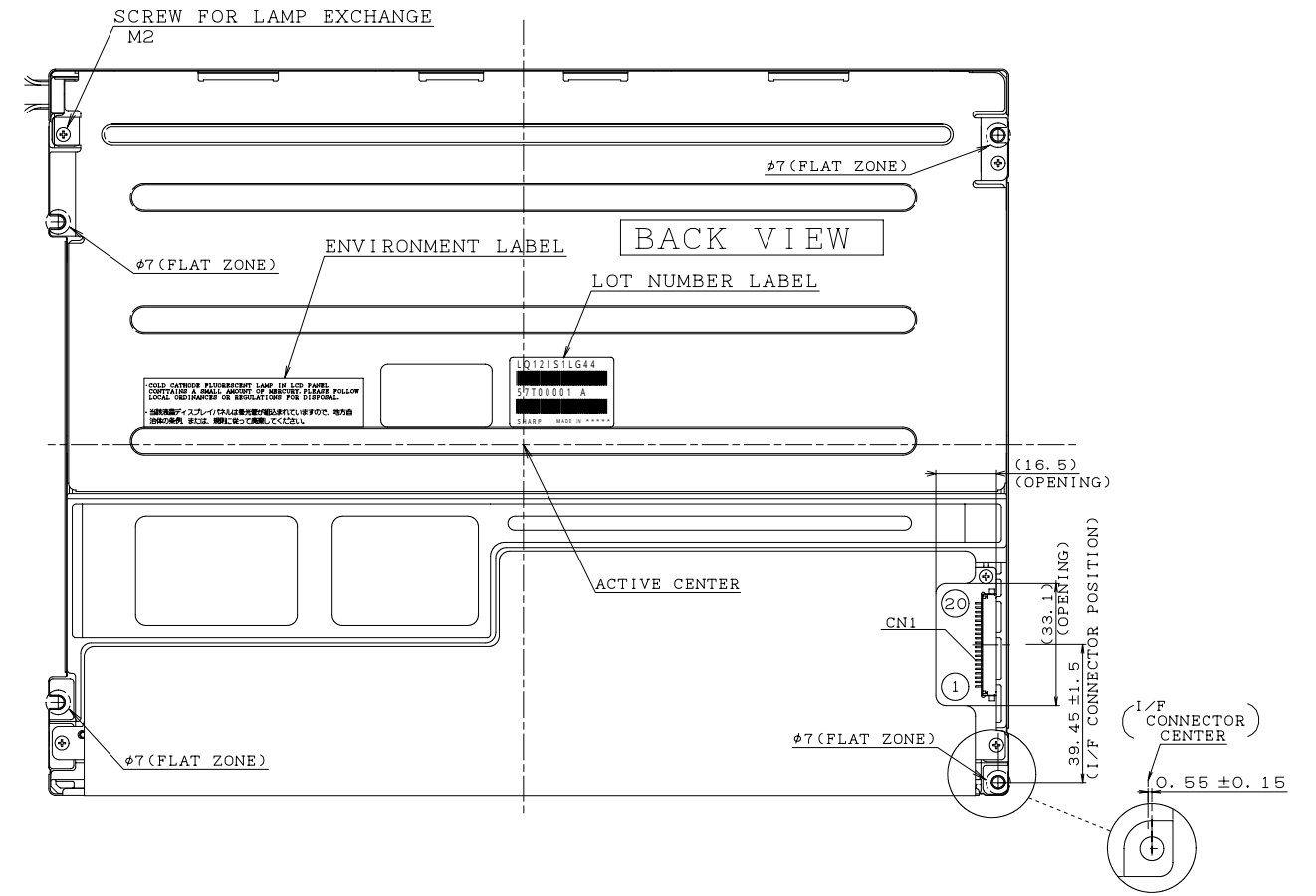
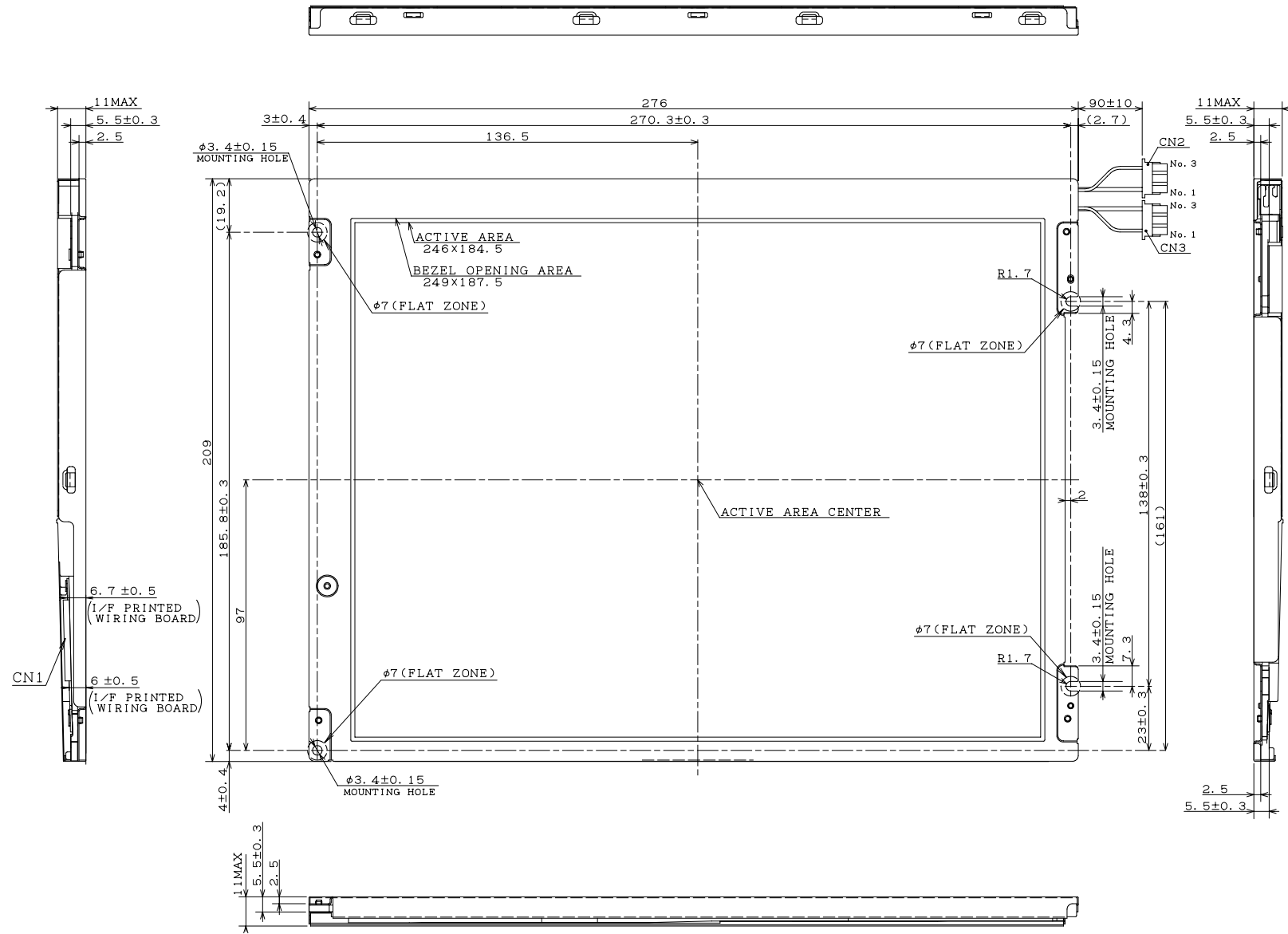

INTERFACE CONNECTOR
PIN LAYOUT

pin	1	2	3	4	5	6	7
	VCC	VCC	GND	GND	RXINO-	RXINO+	GND
8	9	10	11	12	13	14	15
RXIN1-	RXIN1+	GND	RXIN2-	RXIN2+	GND	RCLKIN-	RCLKIN+
16	17	18	19	20			
GND	R/L	U/D	GND	GND			

CORRESPONDING CONNECTOR: FI-SE20M, FI-S20S

BEZEL/DISPLAY POSITION

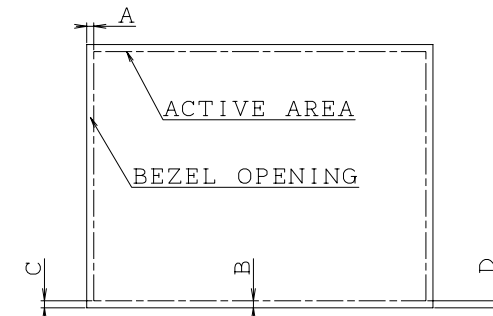

- 1) TOLERANCE X-DIRECTION A: 1.5 ± 0.8
- 2) TOLERANCE Y-DIRECTION B: 1.5 ± 0.8
- 3) OBLIQUITY OF DISPLAY AREA $C-D < 0.8$

CCFT CONNECTOR
CN2, CN3: BHR-03VS-1 (JST)
PIN LAYOUT

1	High
2	NC
3	GND

NOTES

- 1. UNSPECIFIED TOLERANCE TO BE ± 0.5
- 2. WARP AND FLATING FOR PCB AND CHASSIS ARE EXCLUDED FROM THICKNESS AND DIMENSION OF THE UNIT.
- 3. RECOMMENDED TIGHTEN TORQUE FOR MOUNTING $0.294 \pm 0.02N \cdot m$ ($3.0 \pm 0.2kgf \cdot cm$)

Fig 1. OUTLINE DIMENSIONS
(LQ121SILG44)

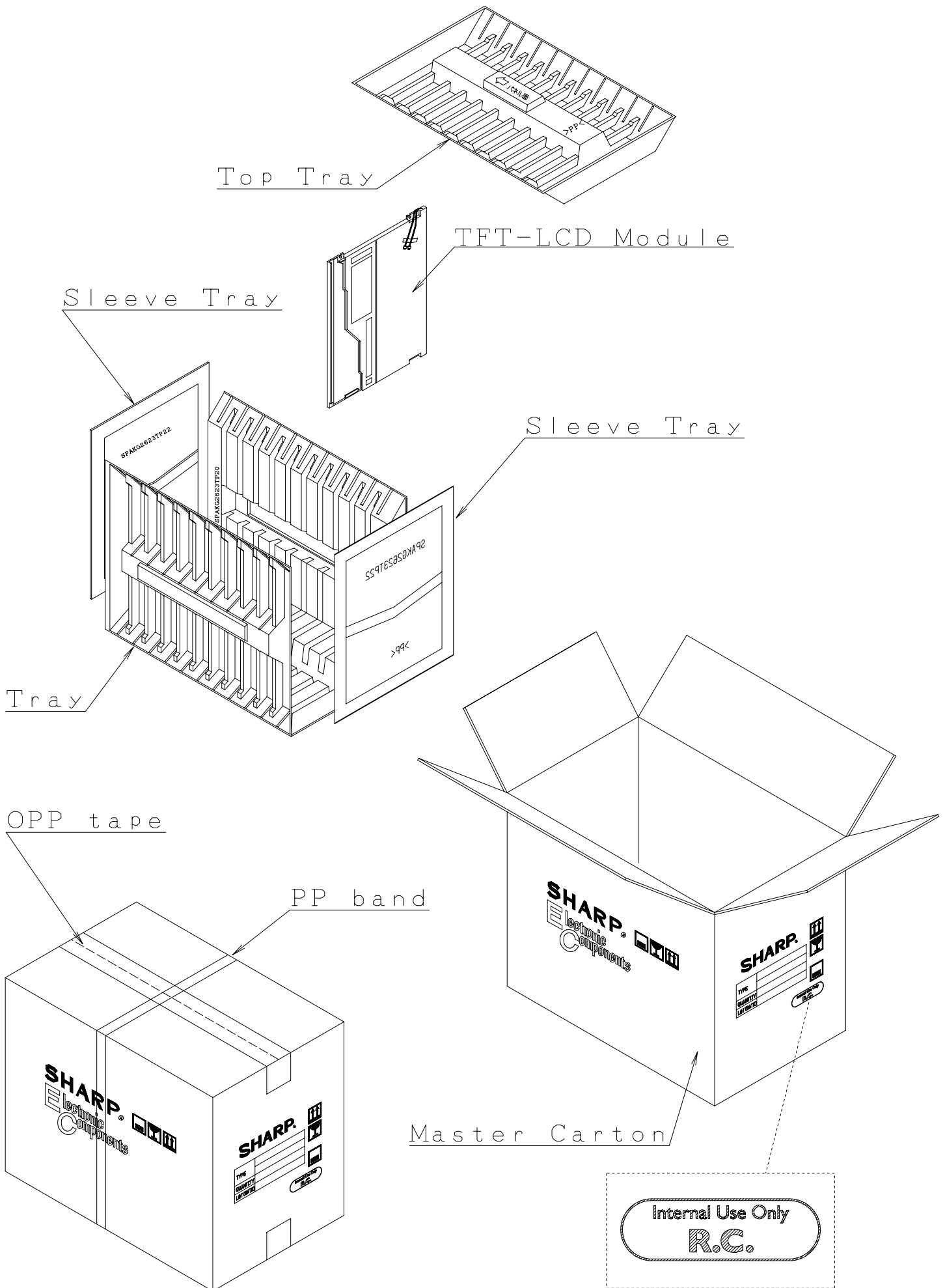

Fig2. Packing Form