

HITACHI

KAOHSIUNG HITACHI
ELECTRONICS CO., LTD
P.O. BOX 26-27
2,13TH EAST ST.K.E.P.Z.
KAOHSIUNG TAIWAN R.O.C.
TEL:(07)821-5811 (7 LINE)
FAX:(07)821-5815

FOR MESSRS : _____

DATE : May.22,2003

CUSTOMER'S ACCEPTANCE SPECIFICATIONS

SX14Q004-ZZA

CONTENTS

No.	ITEM	SHEET No.	PAGE
1	COVER	7B64PS 2701-SX14Q004-ZZA-3	1-1/1
2	RECORD OF REVISION	7B64PS 2702-SX14Q004-ZZA-3	2-1/1
3	GENERAL DATA	7B64PS 2703-SX14Q004-ZZA-3	3-1/1
4	ABSOLUTE MAXIMUM RATINGS	7B64PS 2704-SX14Q004-ZZA-3	4-1/2~4-2/2
5	ELECTRICAL CHARACTERISTICS	7B64PS 2705-SX14Q004-ZZA-3	5-1/3~5-3/3
6	OPTICAL CHARACTERISTICS	7B64PS 2706-SX14Q004-ZZA-3	6-1/3~6-3/3
7	BLOCK DIAGRAM	7B64PS 2707-SX14Q004-ZZA-3	7-1/1
8	INTERFACE TIMING CHART	7B64PS 2708-SX14Q004-ZZA-3	8-1/6~8-6/6
9	DIMENSIONAL OUTLINE	7B63PS 2709-SX14Q004-ZZA-3	9-1/1
10	APPEARANCE STANDARD	7B64PS 2710-SX14Q004-ZZA-3	10-1/5~10-5/5
11	PRECAUTION IN DESIGN	7B64PS 2711-SX14Q004-ZZA-3	11-1/3~11-3/3
12	DESIGNATION OF LOT MARK	7B64PS 2712-SX14Q004-ZZA-3	12-1/1
13	PRECAUTION FOR USE	7B64PS 2713-SX14Q004-ZZA-3	13-1/1

* When product will be discontinued, customer will be informed by HITACHI with twelve months prior announcement.

ACCEPTED BY : _____

PROPOSED BY : Jimmy.HO

RECORD OF REVISION

DATE	SHEET NO.	SUMMARY																																																										
Apr.22,'03	7B64PS 2703-SX14Q004-ZZA-2 Page 3-1/1	3. GENERAL DATA Revise character (10) Lift time → Life time																																																										
	7B64PS 2706-SX14Q004-ZZA-2 Page 6-1/3	6.1 OPTICAL CHARACTERISTICS Revise viewing area and added color tone value <table style="margin-left: auto; margin-right: auto; border-collapse: collapse;"> <tr> <td style="border: 1px solid black; padding: 5px;"> <table border="1" style="width: 100%; border-collapse: collapse;"> <thead> <tr> <th style="width: 15%;">ITEM</th> <th style="width: 35%;">SYMBOL</th> <th style="width: 50%;">TYP.</th> </tr> </thead> <tbody> <tr> <td rowspan="2" style="text-align: center;">Viewing Area</td> <td style="text-align: center;">$\phi_{RR} - \phi_F$</td> <td style="text-align: center;">90</td> </tr> <tr> <td style="text-align: center;">$\phi_{RT} - \phi_L$</td> <td style="text-align: center;">80</td> </tr> <tr> <td rowspan="6" style="text-align: center;">Color Tone</td> <td style="text-align: center;">Red</td> <td style="text-align: center;">X y</td> </tr> <tr> <td rowspan="2" style="text-align: center;">Green</td> <td style="text-align: center;">X y</td> </tr> <tr> <td style="text-align: center;">T.B.D.</td> </tr> <tr> <td rowspan="2" style="text-align: center;">Blue</td> <td style="text-align: center;">X y</td> </tr> <tr> <td style="text-align: center;">T.B.D.</td> </tr> <tr> <td rowspan="2" style="text-align: center;">White</td> <td style="text-align: center;">X y</td> </tr> <tr> <td style="text-align: center;">T.B.D.</td> </tr> </tbody> </table> </td> <td style="text-align: center; vertical-align: middle;">→</td> <td style="border: 1px solid black; padding: 5px;"> <table border="1" style="width: 100%; border-collapse: collapse;"> <thead> <tr> <th style="width: 15%;">ITEM</th> <th style="width: 35%;">SYMBOL</th> <th style="width: 50%;">TYP.</th> </tr> </thead> <tbody> <tr> <td rowspan="2" style="text-align: center;">Viewing Area</td> <td style="text-align: center;">$\phi_{RR} - \phi_F$</td> <td style="text-align: center;">80</td> </tr> <tr> <td style="text-align: center;">$\phi_{RT} - \phi_L$</td> <td style="text-align: center;">90</td> </tr> <tr> <td rowspan="6" style="text-align: center;">Color Tone</td> <td style="text-align: center;">Red</td> <td style="text-align: center;">X y</td> </tr> <tr> <td rowspan="2" style="text-align: center;">Green</td> <td style="text-align: center;">X y</td> </tr> <tr> <td style="text-align: center;">0.52 0.31</td> </tr> <tr> <td rowspan="2" style="text-align: center;">Blue</td> <td style="text-align: center;">X y</td> </tr> <tr> <td style="text-align: center;">0.32 0.52</td> </tr> <tr> <td rowspan="2" style="text-align: center;">White</td> <td style="text-align: center;">X y</td> </tr> <tr> <td style="text-align: center;">0.17 0.17</td> </tr> <tr> <td style="text-align: center;">0.31 0.33</td> </tr> </tbody> </table> </td> </tr> <tr> <td>7B64PS 2705-SX14Q004-ZZA-2 Page 5-2/3</td> <td>5.2.2 ELECTRICAL CHARACTERISTICS Revise YU → YT, YD → YB</td> </tr> <tr> <td>7B64PS 2707-SX14Q004-ZZA-2 Page 7-1/1</td> <td>7. BLOCK DIAGRAM Revise YU → YT</td> </tr> <tr> <td>7B64PS 2708-SX14Q004-ZZA-2 Page 8-1/6</td> <td>8. TIMING CHART Added Note1</td> </tr> <tr> <td rowspan="2" style="vertical-align: top;">May.22,'03</td> <td>7B64PS 2703-SX14Q004-ZZA-3 Page 3-1/1</td> <td>3. GENERAL DATA Revise (2) Module Size thickness : 10.0(D)mm → 10.4(D)mm</td> </tr> <tr> <td>7B64PS 2709-SX14Q004-ZZA-3 Page 9-1/1</td> <td>3. GENERAL DATA Revise (2) Module Size thickness : 8.5±0.3(D)mm → 8.9±0.3(D)mm</td> </tr> <tr> <td> </td> <td> </td> <td> </td> </tr> </table>	<table border="1" style="width: 100%; border-collapse: collapse;"> <thead> <tr> <th style="width: 15%;">ITEM</th> <th style="width: 35%;">SYMBOL</th> <th style="width: 50%;">TYP.</th> </tr> </thead> <tbody> <tr> <td rowspan="2" style="text-align: center;">Viewing Area</td> <td style="text-align: center;">$\phi_{RR} - \phi_F$</td> <td style="text-align: center;">90</td> </tr> <tr> <td style="text-align: center;">$\phi_{RT} - \phi_L$</td> <td style="text-align: center;">80</td> </tr> <tr> <td rowspan="6" style="text-align: center;">Color Tone</td> <td style="text-align: center;">Red</td> <td style="text-align: center;">X y</td> </tr> <tr> <td rowspan="2" style="text-align: center;">Green</td> <td style="text-align: center;">X y</td> </tr> <tr> <td style="text-align: center;">T.B.D.</td> </tr> <tr> <td rowspan="2" style="text-align: center;">Blue</td> <td style="text-align: center;">X y</td> </tr> <tr> <td style="text-align: center;">T.B.D.</td> </tr> <tr> <td rowspan="2" style="text-align: center;">White</td> <td style="text-align: center;">X y</td> </tr> <tr> <td style="text-align: center;">T.B.D.</td> </tr> </tbody> </table>	ITEM	SYMBOL	TYP.	Viewing Area	$\phi_{RR} - \phi_F$	90	$\phi_{RT} - \phi_L$	80	Color Tone	Red	X y	Green	X y	T.B.D.	Blue	X y	T.B.D.	White	X y	T.B.D.	→	<table border="1" style="width: 100%; border-collapse: collapse;"> <thead> <tr> <th style="width: 15%;">ITEM</th> <th style="width: 35%;">SYMBOL</th> <th style="width: 50%;">TYP.</th> </tr> </thead> <tbody> <tr> <td rowspan="2" style="text-align: center;">Viewing Area</td> <td style="text-align: center;">$\phi_{RR} - \phi_F$</td> <td style="text-align: center;">80</td> </tr> <tr> <td style="text-align: center;">$\phi_{RT} - \phi_L$</td> <td style="text-align: center;">90</td> </tr> <tr> <td rowspan="6" style="text-align: center;">Color Tone</td> <td style="text-align: center;">Red</td> <td style="text-align: center;">X y</td> </tr> <tr> <td rowspan="2" style="text-align: center;">Green</td> <td style="text-align: center;">X y</td> </tr> <tr> <td style="text-align: center;">0.52 0.31</td> </tr> <tr> <td rowspan="2" style="text-align: center;">Blue</td> <td style="text-align: center;">X y</td> </tr> <tr> <td style="text-align: center;">0.32 0.52</td> </tr> <tr> <td rowspan="2" style="text-align: center;">White</td> <td style="text-align: center;">X y</td> </tr> <tr> <td style="text-align: center;">0.17 0.17</td> </tr> <tr> <td style="text-align: center;">0.31 0.33</td> </tr> </tbody> </table>	ITEM	SYMBOL	TYP.	Viewing Area	$\phi_{RR} - \phi_F$	80	$\phi_{RT} - \phi_L$	90	Color Tone	Red	X y	Green	X y	0.52 0.31	Blue	X y	0.32 0.52	White	X y	0.17 0.17	0.31 0.33	7B64PS 2705-SX14Q004-ZZA-2 Page 5-2/3	5.2.2 ELECTRICAL CHARACTERISTICS Revise YU → YT, YD → YB	7B64PS 2707-SX14Q004-ZZA-2 Page 7-1/1	7. BLOCK DIAGRAM Revise YU → YT	7B64PS 2708-SX14Q004-ZZA-2 Page 8-1/6	8. TIMING CHART Added Note1	May.22,'03	7B64PS 2703-SX14Q004-ZZA-3 Page 3-1/1	3. GENERAL DATA Revise (2) Module Size thickness : 10.0(D)mm → 10.4(D)mm	7B64PS 2709-SX14Q004-ZZA-3 Page 9-1/1	3. GENERAL DATA Revise (2) Module Size thickness : 8.5±0.3(D)mm → 8.9±0.3(D)mm			
	<table border="1" style="width: 100%; border-collapse: collapse;"> <thead> <tr> <th style="width: 15%;">ITEM</th> <th style="width: 35%;">SYMBOL</th> <th style="width: 50%;">TYP.</th> </tr> </thead> <tbody> <tr> <td rowspan="2" style="text-align: center;">Viewing Area</td> <td style="text-align: center;">$\phi_{RR} - \phi_F$</td> <td style="text-align: center;">90</td> </tr> <tr> <td style="text-align: center;">$\phi_{RT} - \phi_L$</td> <td style="text-align: center;">80</td> </tr> <tr> <td rowspan="6" style="text-align: center;">Color Tone</td> <td style="text-align: center;">Red</td> <td style="text-align: center;">X y</td> </tr> <tr> <td rowspan="2" style="text-align: center;">Green</td> <td style="text-align: center;">X y</td> </tr> <tr> <td style="text-align: center;">T.B.D.</td> </tr> <tr> <td rowspan="2" style="text-align: center;">Blue</td> <td style="text-align: center;">X y</td> </tr> <tr> <td style="text-align: center;">T.B.D.</td> </tr> <tr> <td rowspan="2" style="text-align: center;">White</td> <td style="text-align: center;">X y</td> </tr> <tr> <td style="text-align: center;">T.B.D.</td> </tr> </tbody> </table>	ITEM	SYMBOL	TYP.	Viewing Area	$\phi_{RR} - \phi_F$		90	$\phi_{RT} - \phi_L$	80	Color Tone		Red	X y		Green	X y		T.B.D.	Blue		X y	T.B.D.	White	X y	T.B.D.	→	<table border="1" style="width: 100%; border-collapse: collapse;"> <thead> <tr> <th style="width: 15%;">ITEM</th> <th style="width: 35%;">SYMBOL</th> <th style="width: 50%;">TYP.</th> </tr> </thead> <tbody> <tr> <td rowspan="2" style="text-align: center;">Viewing Area</td> <td style="text-align: center;">$\phi_{RR} - \phi_F$</td> <td style="text-align: center;">80</td> </tr> <tr> <td style="text-align: center;">$\phi_{RT} - \phi_L$</td> <td style="text-align: center;">90</td> </tr> <tr> <td rowspan="6" style="text-align: center;">Color Tone</td> <td style="text-align: center;">Red</td> <td style="text-align: center;">X y</td> </tr> <tr> <td rowspan="2" style="text-align: center;">Green</td> <td style="text-align: center;">X y</td> </tr> <tr> <td style="text-align: center;">0.52 0.31</td> </tr> <tr> <td rowspan="2" style="text-align: center;">Blue</td> <td style="text-align: center;">X y</td> </tr> <tr> <td style="text-align: center;">0.32 0.52</td> </tr> <tr> <td rowspan="2" style="text-align: center;">White</td> <td style="text-align: center;">X y</td> </tr> <tr> <td style="text-align: center;">0.17 0.17</td> </tr> <tr> <td style="text-align: center;">0.31 0.33</td> </tr> </tbody> </table>		ITEM	SYMBOL	TYP.	Viewing Area		$\phi_{RR} - \phi_F$	80		$\phi_{RT} - \phi_L$	90		Color Tone	Red		X y	Green	X y	0.52 0.31	Blue	X y	0.32 0.52	White	X y		0.17 0.17	0.31 0.33					
	ITEM	SYMBOL	TYP.																																																									
Viewing Area	$\phi_{RR} - \phi_F$	90																																																										
	$\phi_{RT} - \phi_L$	80																																																										
Color Tone	Red	X y																																																										
	Green	X y																																																										
		T.B.D.																																																										
	Blue	X y																																																										
		T.B.D.																																																										
	White	X y																																																										
T.B.D.																																																												
ITEM	SYMBOL	TYP.																																																										
Viewing Area	$\phi_{RR} - \phi_F$	80																																																										
	$\phi_{RT} - \phi_L$	90																																																										
Color Tone	Red	X y																																																										
	Green	X y																																																										
		0.52 0.31																																																										
	Blue	X y																																																										
		0.32 0.52																																																										
	White	X y																																																										
0.17 0.17																																																												
0.31 0.33																																																												
7B64PS 2705-SX14Q004-ZZA-2 Page 5-2/3	5.2.2 ELECTRICAL CHARACTERISTICS Revise YU → YT, YD → YB																																																											
7B64PS 2707-SX14Q004-ZZA-2 Page 7-1/1	7. BLOCK DIAGRAM Revise YU → YT																																																											
7B64PS 2708-SX14Q004-ZZA-2 Page 8-1/6	8. TIMING CHART Added Note1																																																											
May.22,'03	7B64PS 2703-SX14Q004-ZZA-3 Page 3-1/1	3. GENERAL DATA Revise (2) Module Size thickness : 10.0(D)mm → 10.4(D)mm																																																										
	7B64PS 2709-SX14Q004-ZZA-3 Page 9-1/1	3. GENERAL DATA Revise (2) Module Size thickness : 8.5±0.3(D)mm → 8.9±0.3(D)mm																																																										

3. GENERAL DATA

(1) Part Name	SX14Q004-ZZA
(2) Module Size	167.0(W)mm x 109.0(H)mm x 10.4(D)mm
(3) Active Area	115.18(W)mm x 86.38(H)mm
(4) Dot Pitch	0.12(W)mm x 0.36(H)mm
(5) Dot Size	0.1(W)mm x 0.34(H)mm
(6) Resolution	320 x 3(R.G.B.)(W) x 240(H)dots
(7) Duty Ratio	1/240
(8) LCD Type	Color STN Transmissive type
(9) Viewing Direction	6 O'clock
(10) Backlight	Cold Cathode Fluorescent Lamp (CFL)x1 Life time : 50kh at 25 °C
(11) Power Consumption (Total)	(1.9W typ.) (Except inverter)
(12) Weight	(235)g typ.
(13) Power Supply Voltage	3.3V only
(14) Touch Panel	Resistance type

4. ABSOLUTE MAXIMUM RATINGS

4.1 ELECTRICAL ABSOLUTE MAXIMUM RATINGS (LCM)

VSS=0V : Standard

ITEM	SYMBOL	MIN.	MAX.	UNIT	COMMENT
Power Supply for Logic	VDD-VSS	0	6.0	V	
Contrast Adjustment Voltage	VCON-VSS	0	VDD	V	
Input Voltage	V_i	-0.3	VDD+0.3	V	(Note 1)
Input Current	I_i	0	1	A	
Static Electricity	—	—	—	—	(Note 2)

Note 1 : \overline{DOFF} ,FLM,CL1,CL2,D0~D7.

Note 2 : Make certain you are grounded when handling LCM.

4.2 ENVIRONMENTAL ABSOLUTE MAXIMUM RATINGS (TOUCH PANEL)

ITEM	SPECIFICATION	NOTE
Voltage	7VDC max.	
Current	20mA max.	

4.3 ENVIRONMENTAL ABSOLUTE MAXIMUM RATINGS

ITEM	OPERATING		STORAGE		COMMENT
	MIN.	MAX.	MIN.	MAX.	
Ambient Temperature	0°C	60°C	-20°C	70°C	(Note 2,3,4)
Humidity	(Note 1)		(Note 1)		Without condensation
Vibration	—	2.45m/s ²	—	11.76m/s ² (Note 5)	1h max. (Note 6)
Shock	—	29.4m/s ²	—	490m/s ² (Note 5)	XYZ directions 11ms
Corrosive Gas	Not acceptable		Not acceptable		

Note 1 : $T_a \leq 40^\circ\text{C}$: 85%RH max.

$T_a > 40^\circ\text{C}$: Absolute humidity must be lower than the humidity of 85%RH at 40°C .

Note 2 : T_a at -20°C --- < 48h , at 60°C --- < 168h.

Note 3 : Background color changes slightly depending on ambient temperature.
This phenomenon is reversible.

Note 4 : When LCM is operated less than 5°C .

The life time of CFL will reduced need to make sure of value IL and characteristics of inverter, also the response time less than 5°C will be slower.

Note 5 : This module should be operated normally after finish the test.

Note 6 : 5Hz~100Hz (Except resonance frequency)

5. ELECTRICAL CHARACTERISTICS

5.1 ELECTRICAL CHARACTERISTICS OF LCD

ITEM	SYMBOL	CONDITION	MIN.	TYP.	MAX.	UNIT
Power Supply Voltage for Logic	VDD	VDD-VSS=3.3V	3.15	3.3	3.45	V
Contrast Adjustment Voltage (Note 1)	VCON	—	0.8	—	2.8	V
Input Voltage (Note 2)	Vin	H level	0.8VDD	—	VDD	V
		L level	0	—	0.2VDD	
Power Supply Current for Logic (Note 3, 4)	IDD	VDD-VSS=3.3V	—	30	35	mA
Input Leak Current (Note 2)	I _{con}	VCON=0.8~2.8V	—	—	20	μA
	I _{in}	Vin=VDD or VSS	—	—	±1.0	
Contrast Adjustment Voltage (Note 5)	VCON	Ta=5°C, φ=0°	1.5	(2.0)	—	V
		Ta=25°C, φ=0°	—	(2.0)	—	
		Ta=40°C, φ=0°	—	(2.0)	2.5	
Frame Frequency (Note 6)	fFLM	—	60	70	80	Hz

Note 1 : In proportion as the VCON voltage decrease the brightness will increase.

Note 2 : DOFF, FLM, CL1, CL2, D0~D7.

Note 3 : fFLM=70Hz Ta=25°C, Display pattern : Checker pattern.

Note 4 : Rush Current of Power ON : 1A (PK) x 1ms + 0.15A (PK) x 20ms.

Note 5 : The Contrast Adjustment Voltage is specified as 2.0±0.5V under the condition, that optimum contrast is obtained by naked eyes with a "Q" test pattern. fFLM=70H, 1/240 Duty.

Note 6 : Need to make sure of flickering and rippling of display when setting the frame frequency in your set.

Note 7 : Some points for attention while setting driving condition of appliance

(1) Frame Frequency

Please set the frame frequency as the typical value (central value) which in CAS According to the characteristic or response time of LC material, that setting the frame frequency near the minimum value or under the minimum value shown in CAS will cause a frame with moving phenomenon.

(2) Setting value VCON

VCON, adjusted to get the best contrast ratio of LCD module, is adjusted to be distributed within the tolerance ±0.3V of central value in CAS before LCD modules ship the factory.

The below items are recommended at customer side.

- (i) When designing the appliance, please set the VCON value as an adjustable value.
- (ii) And the value must be able to be adjusted to match most suitable VCON to get the best contrast ratio. A fixed VCON value a little different from the most suitable VCON value of LCD module and causes a misjudgement.
- (iii) The VCON adjustment (when D/A [Digital/Analog] converter is used) is recommended to be set as 50mV at most per step. That one step is more than 50mV may cause the input value to be not able match the most suitable value.

The characteristic of contrast ratio can not present absolutely.

5.2 ELECTRICAL CHARACTERISTICS OF TOUCH PANEL

5.2.1 OPERATING CONDITION

ITEM	SPECIFICATION
Operating Voltage	5 VDC
Operating Current	20 mA max.

5.2.2 ELECTRICAL CHARACTERISTICS

ITEM	SPECIFICATION	NOTE
Resistance Between Terminal	XR-XL	210~640 Ω
	YT-YB	240~680 Ω
Insulance Resistance	X-Y	20MΩ min.
Linearity	X	1.5% max.
	Y	1.5% max.
Chattering	10ms max.	Operating Voltage : 25VDC Condition See (Note 1)

5.2.3 MESCHANICAL CHARACTERISTICS

ITEM	SPECIFICATION	NOTE
Pen Input Pressure	80g max.	Pin : R0.8 Polyacetal
Finger Input Pressure	100g max.	R8.0 Silicon rubber
Surface Hardness	2H min.	JIS K5400

5.2.4 OPTICAL CHARACTERISTICS

ITEM	SPECIFICATION	NOTE
Transparency	80% min.	Wave length 550 nm

Note 1 : Test Method and Conditions

The difference ("e") between the theoretical output voltage and the actual output voltage when pressure is applied to any point within the valid area must be as indicated below.

$$\frac{e}{E_b - E_a} \times 100\%$$

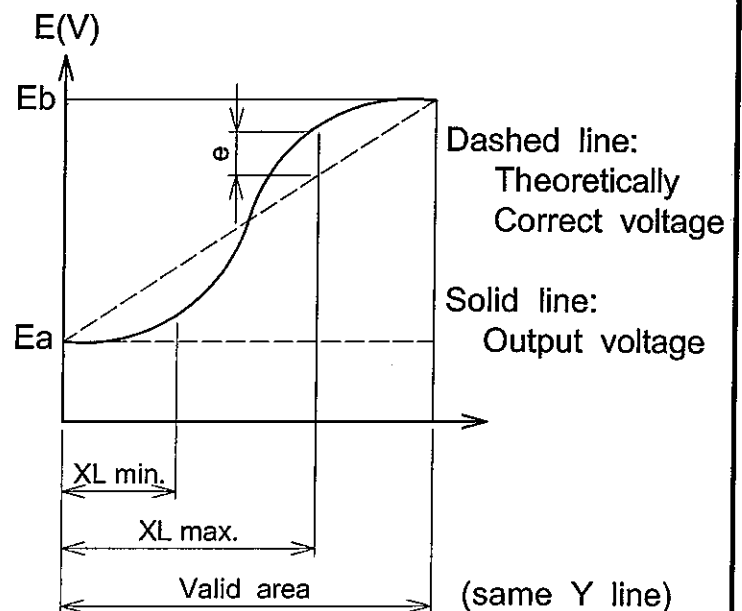
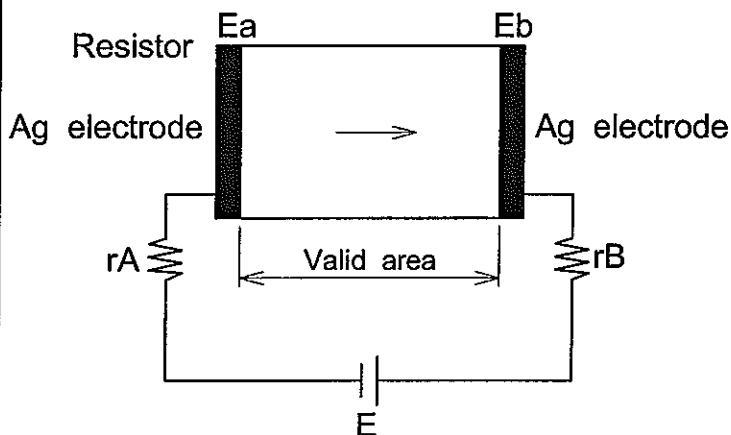

5.3 ELECTRICAL CHARACTERISTICS OF BACKLIGHT

ITEM	SYMBOL	MIN.	TYP.	MAX.	UNIT	NOTE
Lamp Voltage	VL	—	(381)	—	Vrms	Ta=25°C
Frequency	fL	—	75	—	kHz	
Lamp Current (1 Lamp)	IL	5.0	5.5	6.0	mA	Ta=25°C
Starting Discharge Voltage	VS (Note 2)	(1000)	—	—	Vrms	Ta=0°C
Life time	—	—	50	—	kh	Ta=25°C

Note 1 : Please design your lamp driving circuit (inverter) according to the above specifications, and inform HITACHI of it.

Note 2 : Starting discharge voltage is increased when LCM is operating at low temperature.
Please check the characteristics of you inverter before applying to your set.

Note 3 : Average life time of CFL will be decreased when LCM is operating at low temperadture.

Note 4 : Under lower driving frequency of an inverter, a certain backlight system (CFI & CFL reflection sheet) may generate a sound noise. Before designing the inverter, please consider the driving frequency and noise.

Note 5 : We suggest that the lamp current can not be lower than the standard of CAS set, or it will cause low brightness.

Note 6 : We recommend to equip protection circuit (To stop output) which works under abnormal operation to the inverter for CFL.

Note 7 : Lamp current measurement method.

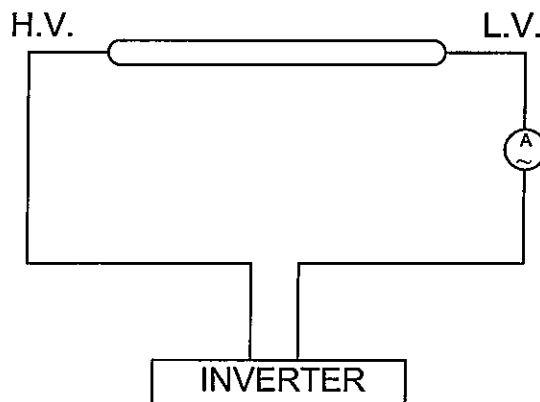

6. OPTICAL CHARACTERISTICS

6.1 OPTICAL CHARACTERISTICS

Ta=25 °C (Backlight on)

ITEM	SYMBOL	CONDITION	MIN.	TYP.	MAX.	UNIT	NOTE	
Viewing Area	$\phi_{RR}-\phi_F$	$K \geq 2.0$	-	80	-	deg	1,2	
	$\phi_{RT}-\phi_L$			90				
Contrast Ratio	K	$\phi=0^\circ, \theta=0^\circ$	25	40	-	-	3,5,6	
Response Time (Rise)	tr	$\phi=0^\circ, \theta=0^\circ$	-	(250)	-	ms	3	
Response Time (Fall)	tf	$\phi=0^\circ, \theta=0^\circ$	-	(200)	-	ms	3	
Color Tone (Primary Color)	Red	x	$\phi=0^\circ, \theta=0^\circ$	-	0.52	-	-	7
		y		-	0.31	-	-	
	Green	x		-	0.32	-	-	
		y		-	0.52	-	-	
	Blue	x		-	0.17	-	-	
		y		-	0.17	-	-	
	White	x		-	0.31	-	-	
		y		-	0.33	-	-	

(Measurement condition : HITACHI standard)

Note 1~7 : See next page.

Note 1 : Definition of Viewing Angle

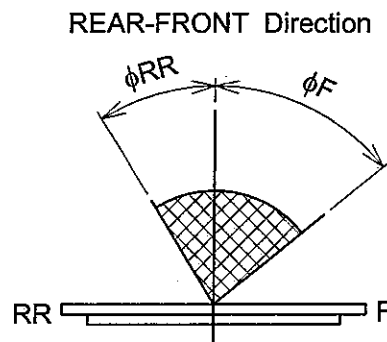
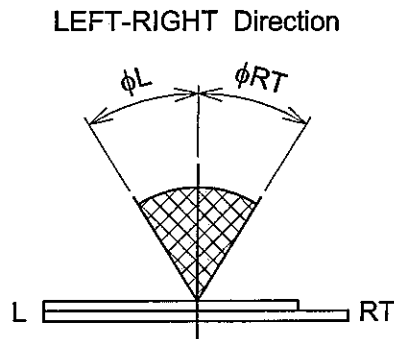
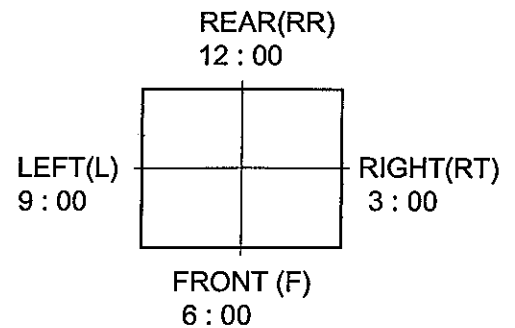
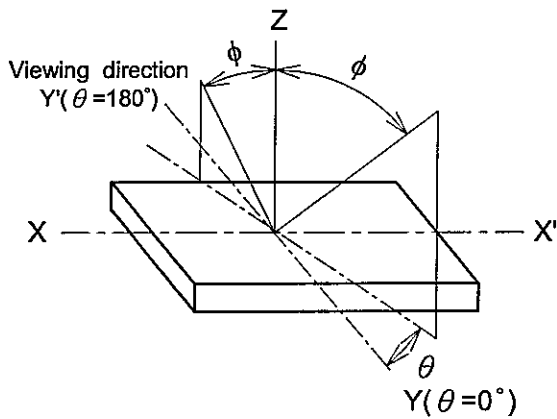

* The viewing direction of this product is 6 O'clock.

So $\phi_F > \phi_{RR}$ $\phi_L \approx \phi_{RT}$

Note 2 : Definition of viewing angle

ϕ_{RR} and ϕ_F , ϕ_{RT} and ϕ_L

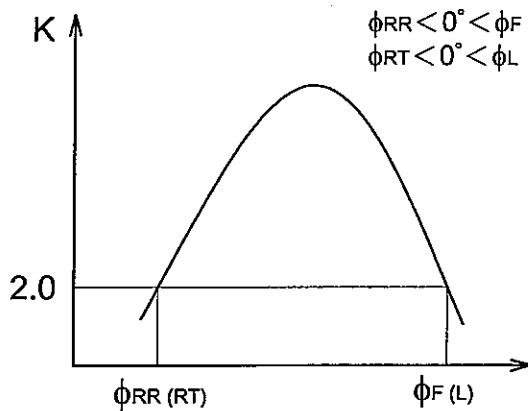

Viewing Angle

Contrast ratio K vs viewing angle ϕ

Note 3 : Definition of contrast "K"

$$K = \frac{\text{Brightness on selected area (B1)}}{\text{Brightness on non-selected area (B2)}}$$

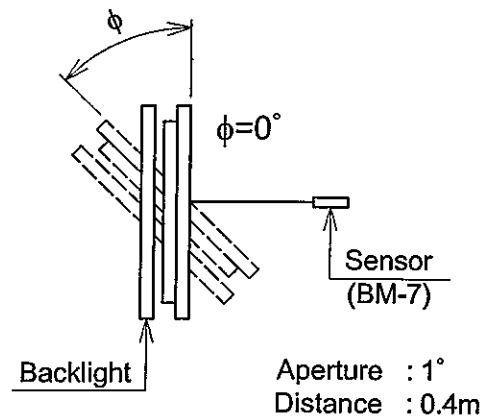
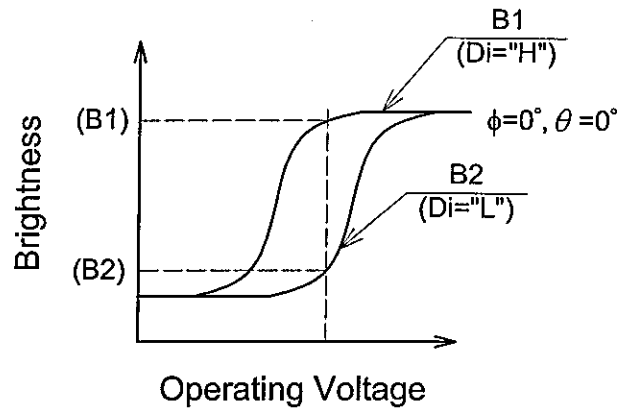

Note 4 : Definition of optical response time

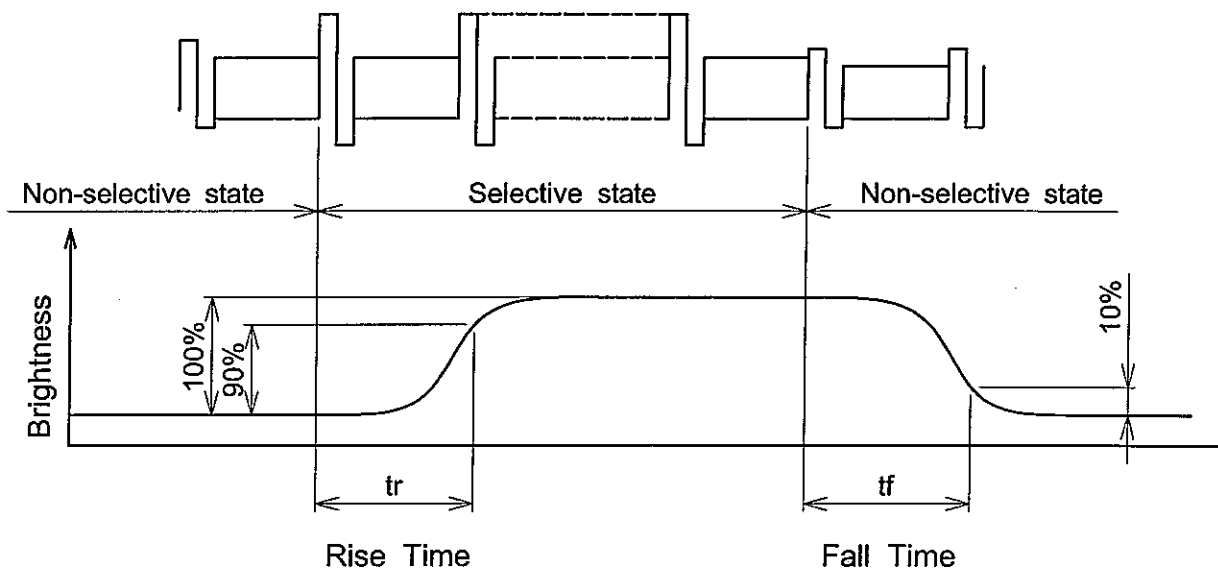

Note 5 : HITACHI will not do 100% inspection for minimum value. Minimum value is for reference.

Note 6 : HITACHI will do sampling inspection for minimum value.

Note 7 : The LCD driving voltage should be adjusted at the voltage where the peak contrast is obtained.

6.2 OPTICAL CHARACTERISTICS OF BACKLIGHT

ITEM	MIN.	TYP.	MAX.	UNIT	NOTE
Brightness	—	160	—	cd/m ²	IL=5.5mA (Note 1, 2)
Rise Time	—	5	—	Minute	IL=5.5mA Brightness 80%
Brightness Uniformity	—	—	±30	%	Undermentione (Note 1, 3, 4)

(Measurement condition : Hitachi standard)

CFL : INITIAL , Ta=25°C

Display data should be all "Q".

The LCD driving voltage should be abjusted so as to obtain maximum contrast, when display pattern is all "Q".

Note 1 : Measurement after 10 minutes from CFL operating.

Average value of 9 points (Note 3)

Note 2 : Brightness control : 100%

Note 3 : Measurement of the following 9 places on the display.

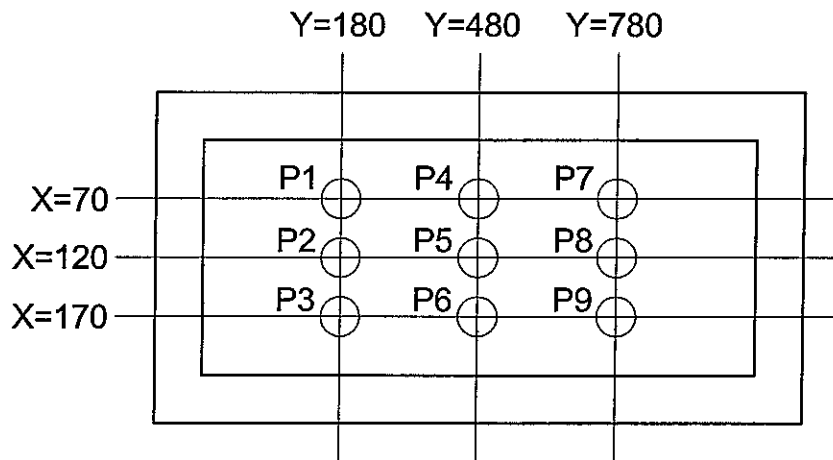

Note 4 : Definition of the brightness tolerance.

$$\left(\frac{\text{max. brightness or min. brightness} - \text{Average brightness}}{\text{Average brightness}} \right) \times 100$$

7. BLOCK DIAGRAM

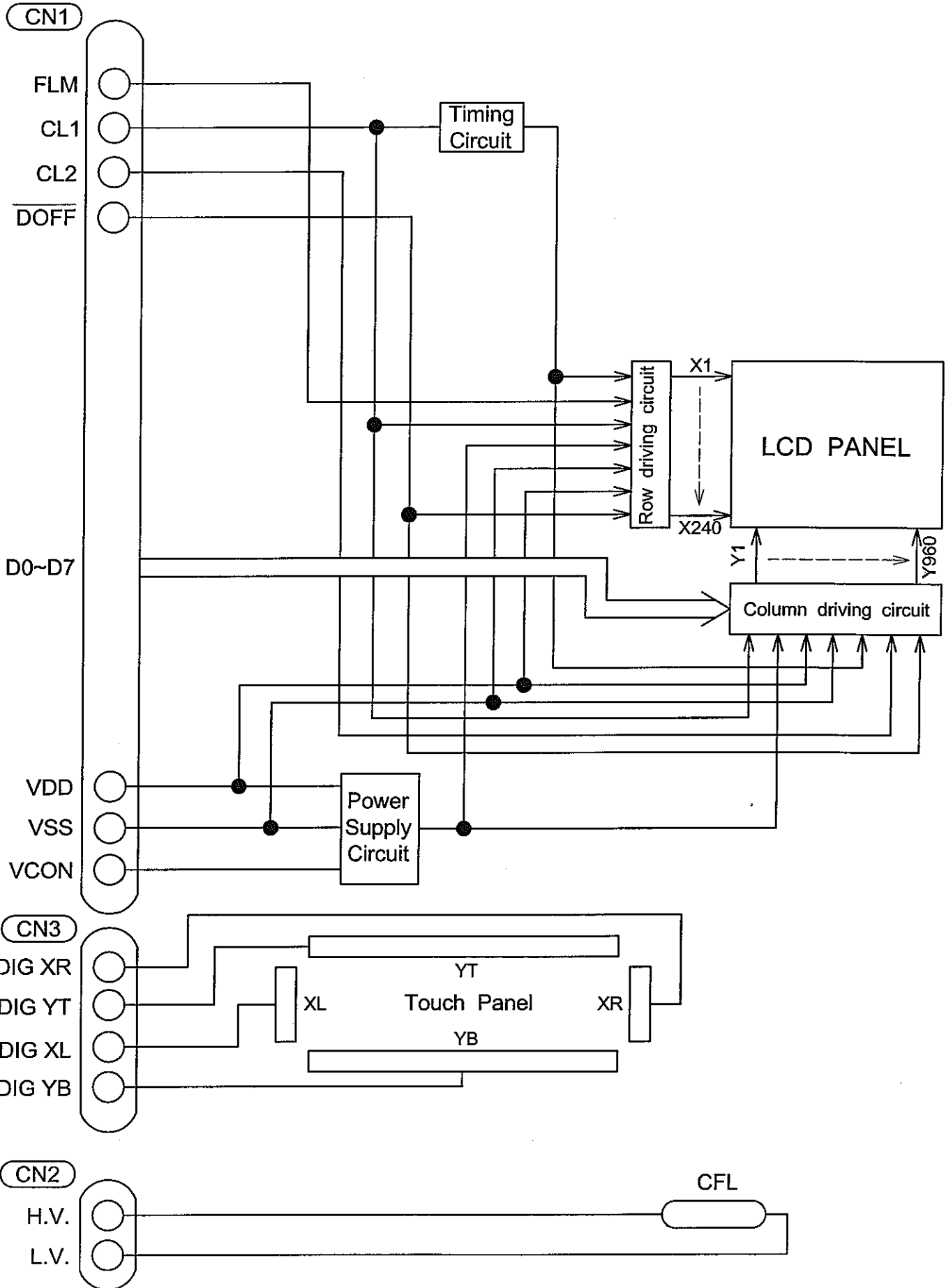

8. INTERFACE TIMING CHART

8.1 TIMING CHART

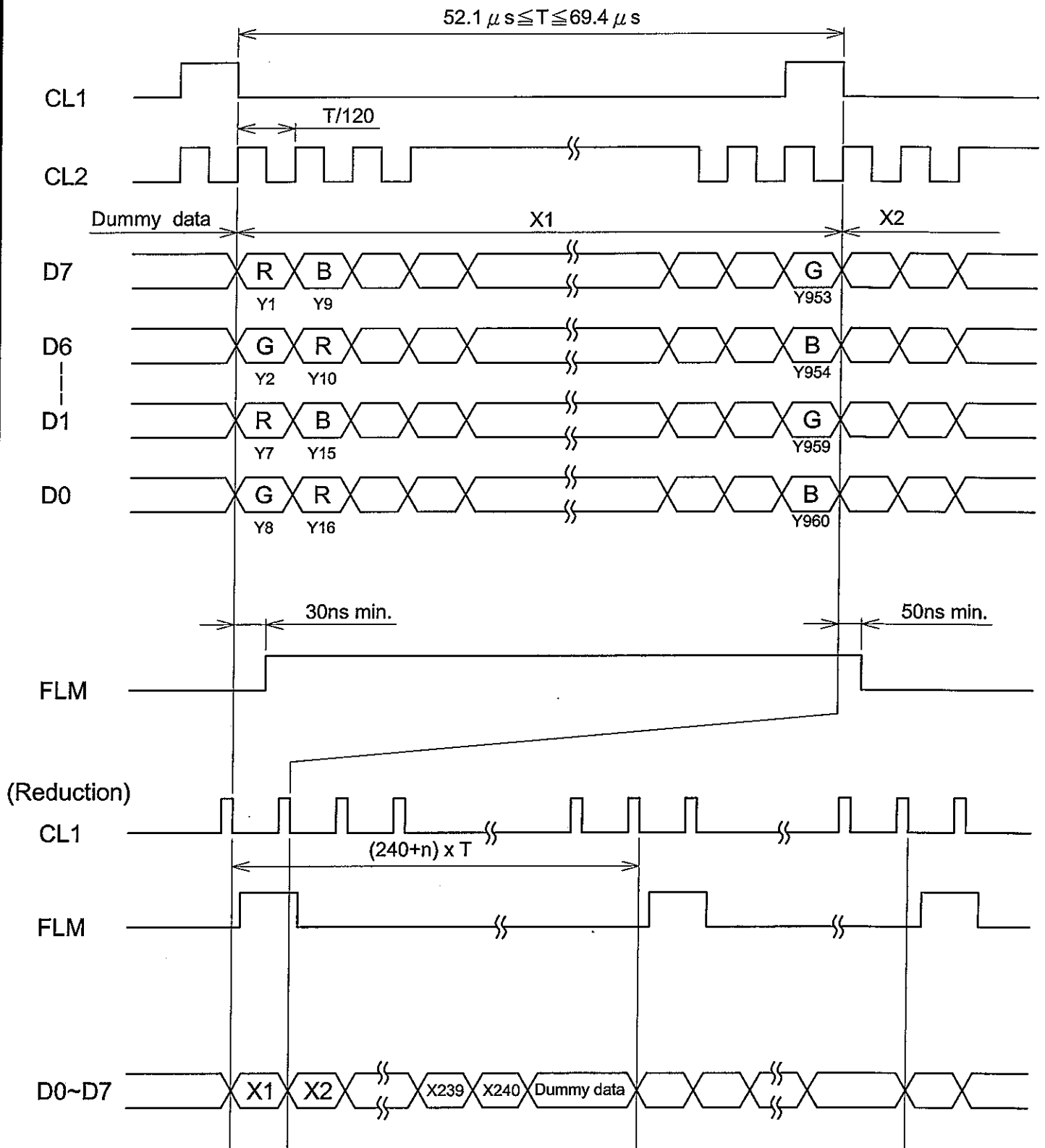

Note 1 : HITACHI recommends the duty ratio is 1/240 (n=0).

Due to the variation of customers and HITACHI testing equipment , changing the duty ratio (n=1,2,.....) may obtain optimum performance.

8.2 TIMING CHARACTERISTICS

VDD=3.3±0.15V, VSS=0V, VCON=0.8~2.8V, Ta=0°C~+60°C

ITEM	SYMBOL	MIN.	TYP.	MAX.	UNIT
CL1 Pulse width "H"	t _{WHCL1}	100	—	—	ns
CL2 cycle time	t _{CYC}	60	—	—	ns
CL2 Pulse width	t _{WCL2}	30	—	—	ns
CL1 set up time	t _{SCL1}	40	—	—	ns
CL1 hold time	t _{HCL1}	80	—	—	ns
Clock rise fall time	t _r , t _f	—	—	30	ns
Data set up time	t _{DSU}	20	—	—	ns
Data hold time	t _{DH}	20	—	—	ns
"FLM" set up time	t _{FS}	100	—	—	ns
"FLM" hold time	t _{FH}	50	—	—	ns

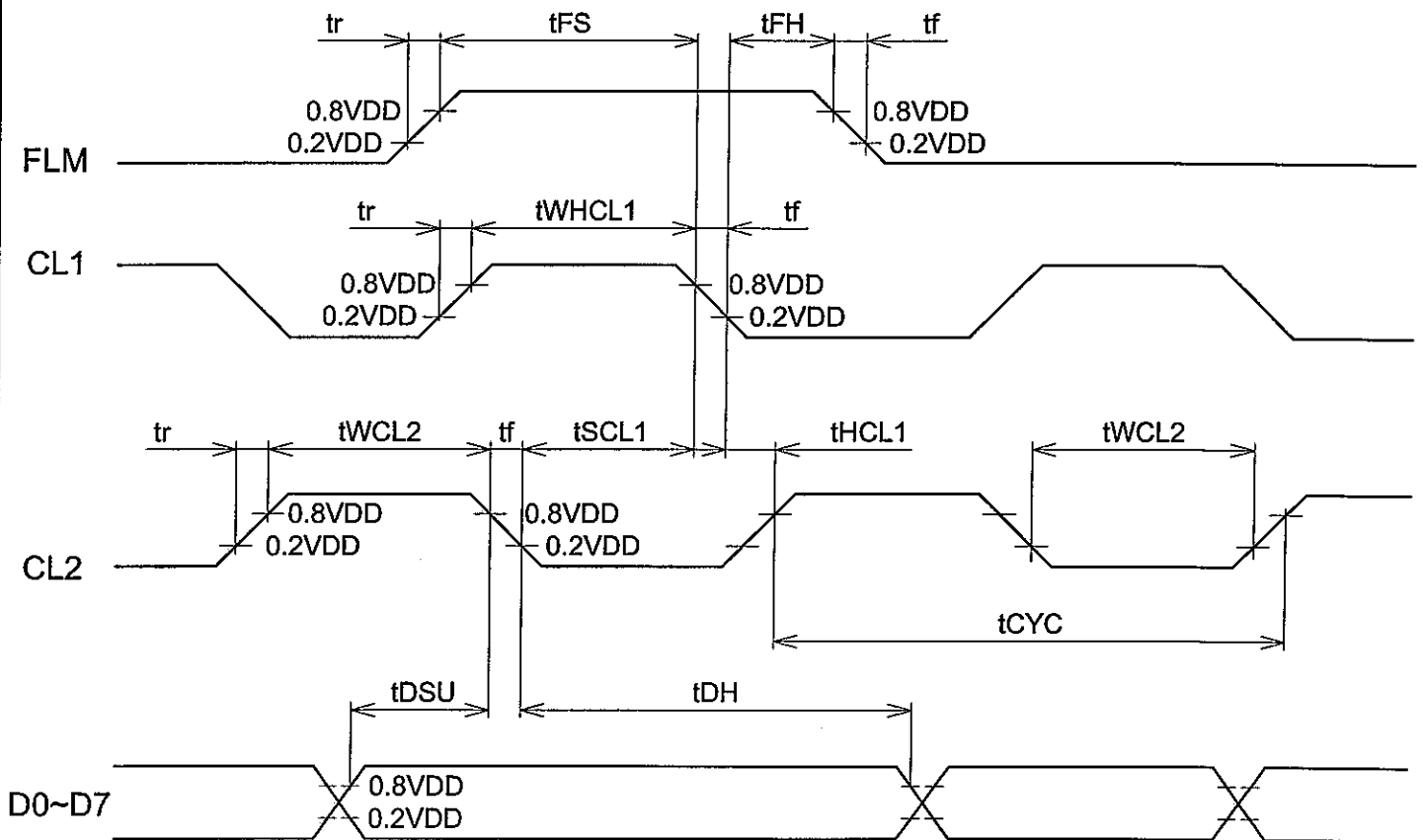

8.3 POWER ON/OFF SEQUENCE

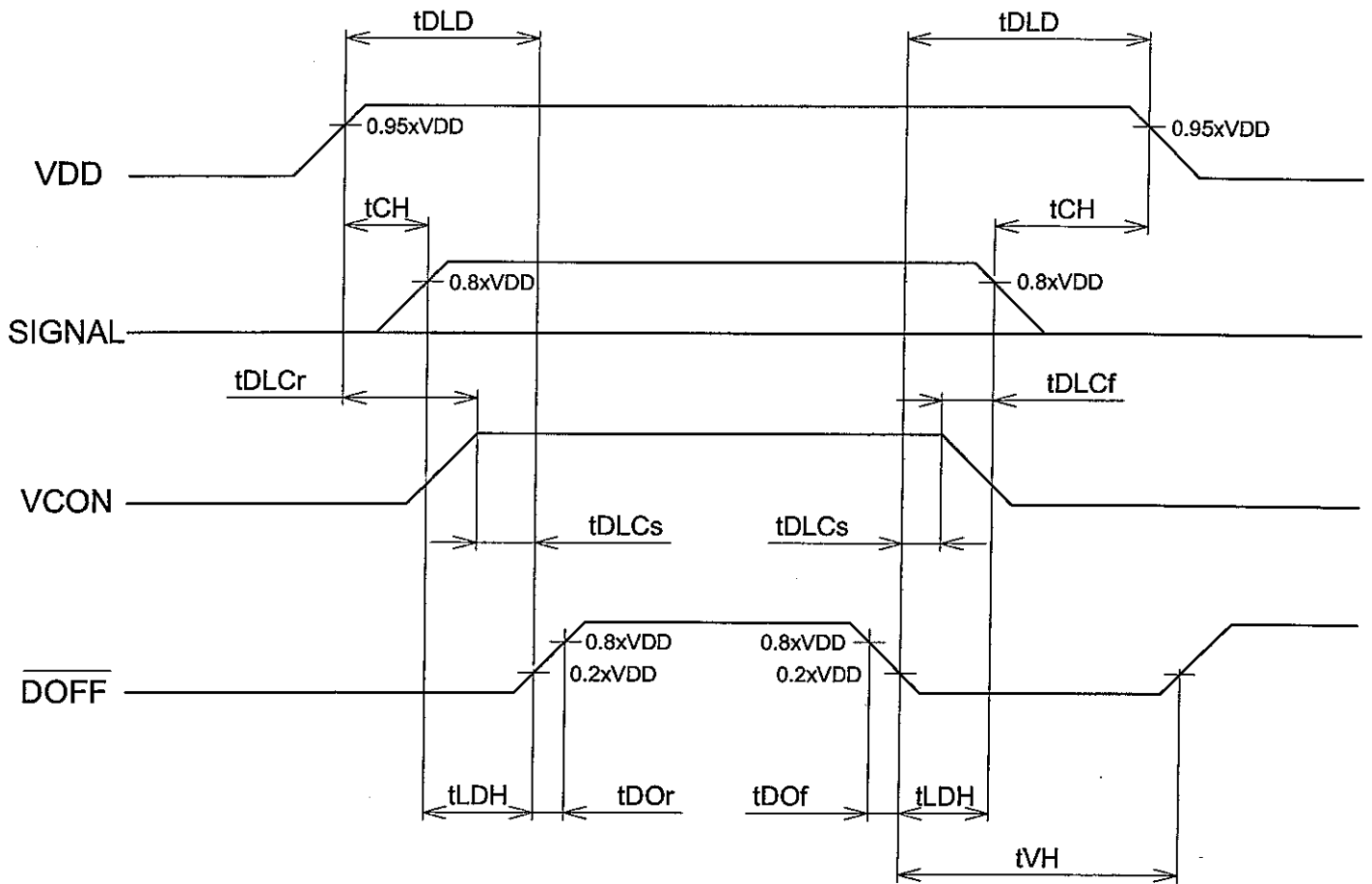

SYMBOL	MIN.	MAX.	UNIT	COMMENT
t_{DLd}	200	—	ms	(Note 1) (Note 2)
t_{CH}	0	—	ms	
t_{LDH}	20	—	ms	
t_{DOr}	—	100	ns	
t_{DOF}	—	100	ns	
t_{DLcCr}	20	—	ms	
t_{DLcCf}	0	—	ms	
t_{DLcCs}	20	—	ms	
t_{VH}	200	—	ms	

Note 1 : Please keep the specified sequence because wrong sequence may cause permanent damage to the LCD panel.

Note 2 : HITACHI recommends you to use DOFF function.

Display quality may deteriorate if you don't use DOFF function.

8.4 POWER SUPPLY FOR LCM

Example

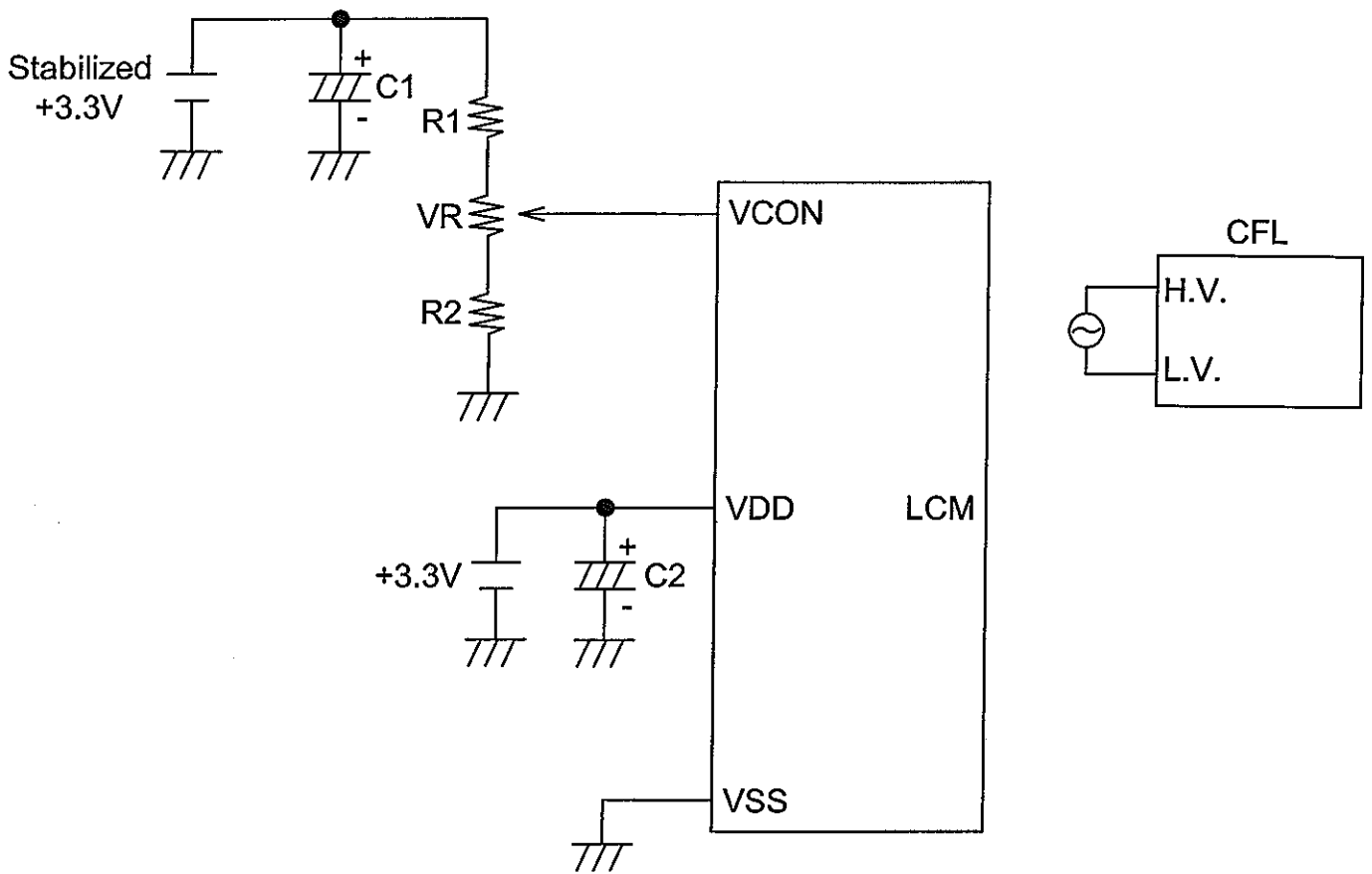

8.5 INPUT DATA ALLOCATION TABLE

Data Signal	D 7	D 6	D 5	D 4	D 3	D 2	D 1	D 0	D 7	D 6	D 5	D 4	-----	D 4	D 3	D 2	D 1	D 0
	Y	1	2	3	4	5	6	7	8	9	10	11	12		9 5 6	9 5 7	9 5 8	9 5 9
1	R	G	B	R	G	B	R	G	B	R	G	B	-----	G	B	R	G	B
2	R	G	B	R	G	B	R	G	B	R	G	B	-----	G	B	R	G	B
3	R	G	B	R	G	B	R	G	B	R	G	B	-----	G	B	R	G	B
4	R	G	B	R	G	B	R	G	B	R	G	B	-----	G	B	R	G	B
5	R	G	B	R	G	B	R	G	B	R	G	B	-----	G	B	R	G	B

138	R	G	B	R	G	B	R	G	B	R	G	B	-----	G	B	R	G	B
139	R	G	B	R	G	B	R	G	B	R	G	B	-----	G	B	R	G	B
140	R	G	B	R	G	B	R	G	B	R	G	B	-----	G	B	R	G	B
141	R	G	B	R	G	B	R	G	B	R	G	B	-----	G	B	R	G	B
142	R	G	B	R	G	B	R	G	B	R	G	B	-----	G	B	R	G	B
143	R	G	B	R	G	B	R	G	B	R	G	B	-----	G	B	R	G	B
144	R	G	B	R	G	B	R	G	B	R	G	B	-----	G	B	R	G	B
145	R	G	B	R	G	B	R	G	B	R	G	B	-----	G	B	R	G	B

238	R	G	B	R	G	B	R	G	B	R	G	B		G	B	R	G	B
239	R	G	B	R	G	B	R	G	B	R	G	B		G	B	R	G	B
240	R	G	B	R	G	B	R	G	B	R	G	B		G	B	R	G	B

R : RED
 G : GREEN
 B : BLUE

8.6 INTERNAL PIN CONNECTION

CN1 FFC : Pitch 1.0mm 16pins

PIN No.	SIGNAL	LEVEL	FUNCTION
1	FLM	H	First Line Marker
2	CL1	H→L	Data Latch
3	CL2	H→L	Data Shift
4	$\overline{\text{DOFF}}$	H/L	H : ON , L : OFF
5	VDD	—	Power Supply for Logic
6	VSS	—	GND
7	VCON	—	Contrast Adjust
8	D0	H/L	Display Data
9	D1		
10	D2		
11	D3		
12	D4		
13	D5		
14	D6		
15	D7		
16	VSS	—	GND

CN2 : JAE / IL - G - 4S - S3C2

PIN No.	SIGNAL	LEVEL	FUNCTION
1	H.V.	—	Power Supply for CFL
2	N.C	—	—
3	N.C	—	—
4	L.V.	—	GND for CFL

CN3 FPC : Pitch 1.0mm 4pins

PIN No.	SIGNAL	FUNCTION
1	XR	Analog Signal from Digitizer Right
2	YT	Analog Signal from Digitizer Top
3	XL	Analog Signal from Digitizer Left
4	YB	Analog Signal from Digitizer Bottom

10. APPEARANCE STANDARD

10.1 APPEARANCE INSPECTION CONDITION

Visual inspection should be done under the following condition.

- (1) The inspection should be done in a dark room.
- (2) The CFL should be lighted with the prescribed inverter.
- (3) The distance between eyes of an inspector and the LCD module is 25cm.
- (4) The viewing zone is shown the figure.

Viewing angle $\leq 25^\circ$.

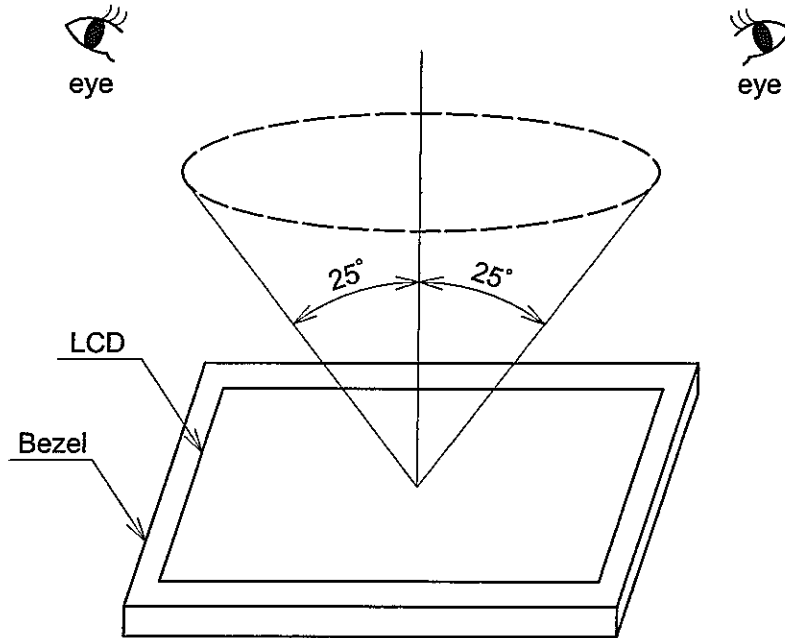

10.2 DEFINITION OF ZONE

A zone : Within the LCD active area line specified at page 9-1/1 of this document.

B zone : Area between the LCD effective area line and the LCD active area line specified at page 9-1/1 of this document.

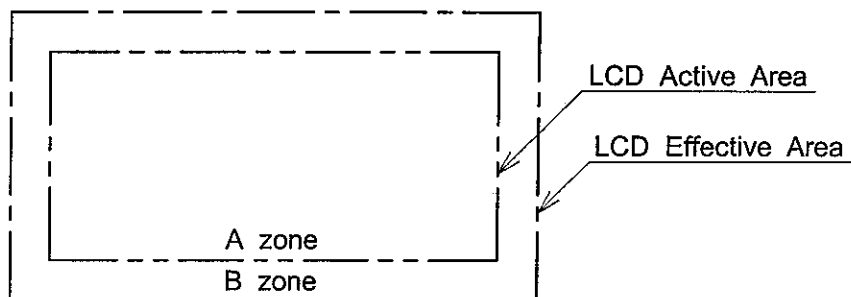

10.3 APPEARANCE INSPECTION CONDITION

(1) LCD APPEARANCE

*: If the problem related to this section occurs about this item, the responsible persons of both party (Customer and HITACHI) will discuss the matter in detail.

No.	ITEM	CRITERIA		A	B	
L C D	Scratches	Distinguished one is not acceptable (to be judged by HITACHI SRANDARD)		*	—	
	Dent	Same as above		*	—	
	Wrinkles in Polarizer	Same as above		*	—	
	Bubbles	Average Diameter D (mm)		Maximum Number Acceptable		
		$D \leq 0.2$		ignored		
		$0.2 < D \leq 0.3$		12		
		$0.3 < D \leq 0.5$		3		
		$0.5 < D$		none		
	Stains, Foreign Materials, Dark Spot	Filamentous (Line shape)			○	*
		Length L(mm)	Width W(mm)	Maximum Number Acceptable		
		$L \leq 2.0$	$W \leq 0.03$	ignored		
		$L \leq 3.0$	$0.03 < W \leq 0.05$	6		
		$L \leq 2.5$	$0.05 < W \leq 0.1$	1		
		Round (Dot shape)			○	*
		Average Diameter D(mm)	Maximum Number Acceptable	Minimum Space		
$D < 0.2$		ignored	—			
$0.2 \leq D < 0.3$		10	10 mm			
$0.3 \leq D < 0.4$		5	30 mm			
$0.4 \leq D$	none	—				
The total number	Filamentous+Round=10					
Those wiped out easily are acceptable						
Color Tone	To be judged by HITACHI STANDARD		○	—		
Color Uniformity	Same as above		○	—		

No.	ITEM	CRITERIA				A	B
L	Contrast Irregularity (Spot)	Average Diameter D(mm)	Contrast	Maximum Number Acceptable	Minimum Space	○	—
		$D \leq 0.25$	To be Judged by HITACHI	ignored	—		
		$0.25 < D \leq 0.35$		10	20 mm		
		$0.35 < D \leq 0.5$		4	20 mm		
		$0.5 < D \leq 0.7$		3	50 mm		
		$0.7 < D$		none	—		
C D	Contrast Irregularity (Line) (A pair of scratches)	Width W (mm)	Length L (mm)	Maximum Number Acceptable	Minimum Space	○	—
		$W \leq 0.25$	$L \leq 1.2$	2	20 mm		
		$W \leq 0.2$	$L \leq 1.5$	3	20 mm		
		$W \leq 0.15$	$L \leq 2.0$	3	20 mm		
		$W \leq 0.1$	$L \leq 3.0$	4	20 mm		
		The whole number		6			
To be judged by HITACHI STANDARD					○	—	

(2) CFL BACKLIGHT APPEARANCE

No.	ITEM	CRITERIA			A	B
C F L	Dark Spots White Spots Foreign Materials (Spot)	Average Diameter D(mm)	Maximum Number Acceptable		○	—
		$D \leq 0.4$	ignored			
		$0.4 < D$	none			
B A C K L I G H T	Foreign Materials (Line)	Width W (mm)	Length L (mm)	Maximum Number Acceptable	○	—
		$W \leq 0.2$	$L \leq 2.5$	1		
			$2.5 < L$	none		
		$0.2 < W$	—	none		
S C R A T C H E S	Scratches	Width W (mm)	Length L (mm)	Maximum Number Acceptable	○	—
		$W \leq 0.1$	—	ignored		
		$0.1 < W \leq 0.2$	$L \leq 11.0$	1		
			$11.0 < L$	none		
		$0.2 < W$	—	none		

(3) TOUCH PANEL APPEARANCE

ITEM	CRITERIA		
Scratch	$W > 0.10$	$L \geq 10$	None
	$0.10 \geq W > 0.05$	$L < 10$	4pcs max.
	$0.05 \geq W$	$L < 10$	ignored
Dust (Linear)	$W > 0.10$	—	Dust (Circular)
	$0.10 \geq W > 0.05$	$3 < L$	None
	$0.05 \geq W$	$L \leq 3$	ignored
Dust (Circular)	$D > 0.35$		None
	$0.35 \geq D > 0.25$		6pcs max.
	$0.25 \geq D$		ignored

Applied only in the active area. Scratches or dusts in the outside of the active area are acceptable unless the electrical characteristics are affected.

- Dirt
Acceptable if not noticeable on a black mat.
- Tip, crack (applicable to glass only).

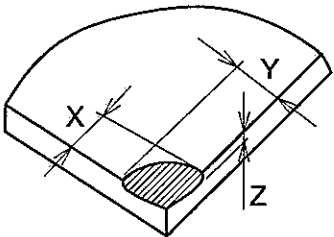
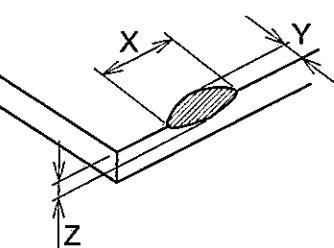
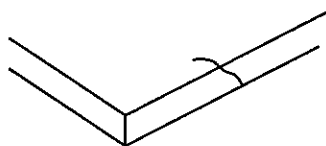
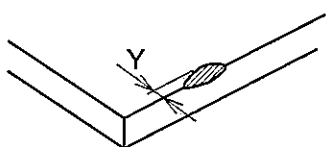
ITEM	CRITERIA			
Tip Corner		X	≤ 3	Not acceptable if the film is damaged
		Y	≤ 3	
		Z	≤ 1.1	
Tip Side		X	≤ 5	Not acceptable if the film is damaged
		Y	≤ 3	
		Z	≤ 1.1	
Crack				None
Other		$Y \leq 1$		Not acceptable if the electrical Characteristics is affected

Note 1 : Definition of average diameter (D)

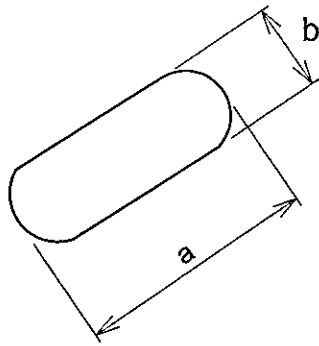

$$\frac{a+b}{2} = D \dots \text{Average Diameter}$$

Note 2 : Definition of length (L) and width (W)

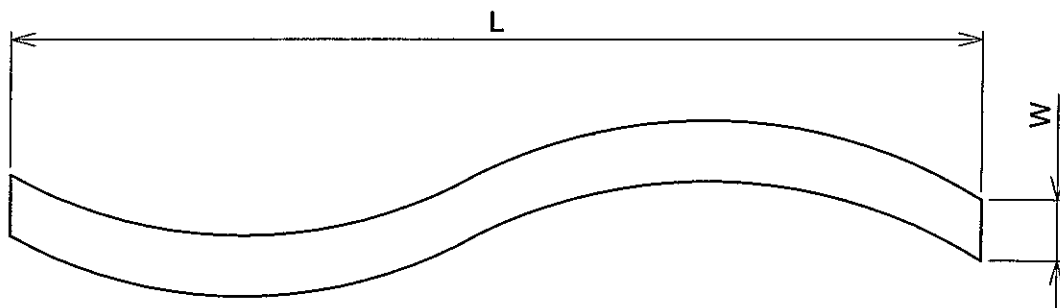

11. PRECAUTION IN DESIGN

11.1 MOUNTING PRECAUTION

Please mount the LCD module by using mounting holes provided. While mounting please pay attention to the followings.

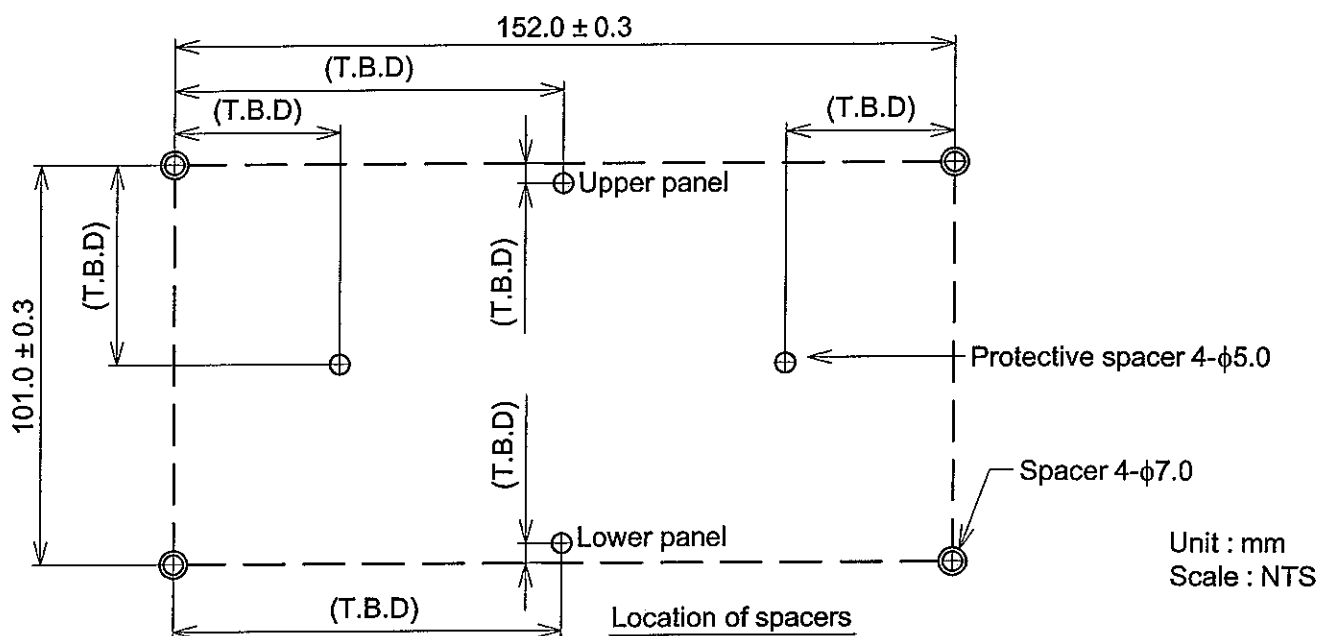
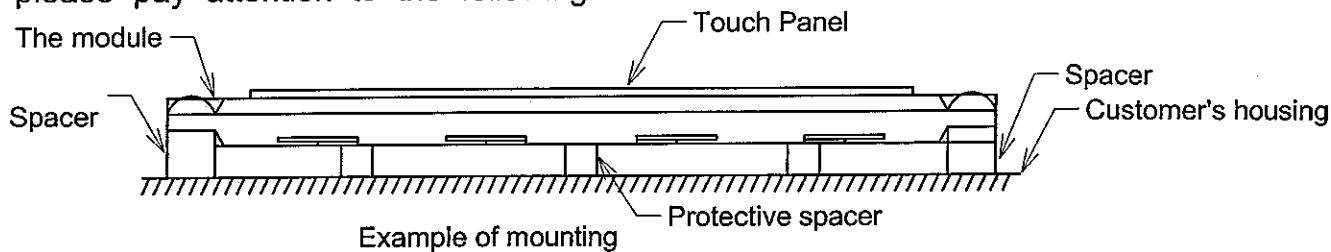

Unit : mm
Scale : NTS

- (1) To prevent the module cover from being pressed, the distance between the module and the fitting plate, which means the length of the spacers, should be shorter than 1.0mm.
- (2) The protective spacers are recommend in order to protect the module from shock.

11.2 PRECAUTIONS AGAINST ELECTROSTATIC DISCHARGE

As this module contains C-MOS LSIs, it is not strong against electrostatic discharge. Make certain that the operator's body is connected to the ground through a list band, etc. And don't touch I/F pins directly.

11.3 POWER ON SEQUENCE

Input signals should not be applied to LCD module before power supply voltage is applied and reaches to specified voltage ($3.3 \pm 0.15V$). If the above sequence is not kept, C-MOS LSIs of LCD module may be damaged due to latch up phenomenon.

11.4 HANDLING PRECAUTIONS

- (1) Since the polarizer on the top, and the aluminum plate on the bottom tend to be easily damaged, the should be with full care so as not to get them touched, pushed or rubbed by a piece on glass, tweezers and anything else which are hander a pencil lead 3H.

- (2) As the adhesives used for adhering upper/lower polarizers and aluminum plate are made of organic substances which will be deteriorated by a chemical reaction with such chemicals as acetone, toluene, ethanol and isopropylalcohol. The following are recommended for use :
normal hexane.
Please contact with us when it is necessary for you to use chemicals other than the above.
- (3) Lightly wipe to clean the dirty surface with absorbent cotton or other soft material like chamois, soaked in the recommended chemicals without scrubbing it hardly. Always wipe the surface horizontally or vertically. Never give a wipe in a circle. To prevent the display surface from damage and keep the appearance in good state, it is sufficient, in general, to wipe it with absorbent cotton.
- (4) Immediately wipe off saliva or water drop attached on the display area because it may cause deformation or faded color.
- (5) Foggy dew deposited on the surface may cause a damage, stain or dirt to the polarizer. When you need to take out the LCD module from some place at low temperature for test, etc. It is required to be warmed them up to temperature higher than room temperature before taking them out.
- (6) Touching the display area or I/F pins with bare hands or contaminating them are prohibited, because the stain on the display area and poor insulation between terminals are often caused by being touched with bare hands.
(Some cosmetics are detrimental to polarizers.)
- (7) In general, the glass is fragile so that, especially on its periphery, tends to be cracked or chipped in handling. Please not give the LCD module sharp shocks by falling, etc.
- (8) Maximum pressure to the surface must be less than 1.96×10^4 Pa. And if the pressure area is less than 1cm^2 , maximum pressure must be less than 1.96N.
- (9) Since the metal width is narrow on these locations (see page 9-1/1), please careful with handling.
- (10) Top sheets shall be cleaned gently using a soft cloth such as those used for glasses. Hard wiping accumulated dust will leave scars on the surface even using a cloth.

11.5 OPERATION PRECAUTION

- (1) Using a LCM module beyond its maximum ratings may result in its permanent destruction. LCM module's should usually be used under recommended operating conditions shown in chapter 5. Exceeding any of these conditions may adversely affect its reliability.

- (2) Response time will be extremely delayed at lower temperature than the specified operating temperature range and on the other hand LCD's shows dark blue at higher temperature.
However those phenomena do not main defects of the LCD module. Those phenomena will disappear in the specified operating temperature range.
- (3) If the display area is pushed hard during operation, some display patterns will be abnormally display.
- (4) A slight dew depositing on terminals may cause electrochemical reaction which leads to terminal open circuit. Please operate the LCD module under the relative condition of 40°C 85%RH.
- (5) Resistance range : Your controller shall be set up to allow the resistance range of Touch Panel specified in our CAS.
- (6) Pointed position of Touch Panel may shift owing to a change in resistance of Touch Panel depending on the operation condition. To compensate this shift, the set shall be given a calibration function.
- (7) Input shall be made with a stylus pen (polyacetal, R0.8). Chances are very high that use of a metal piece including a ball point pen or sharp edge will impair accuracy.
- (8) The Touch Panel is an auxiliary input device. The system shall be designed to have other input device.

11.6 STORAGE

In case of storing LCD module for a long period of time (for instance, for years) for the purpose of replacement use, the following precautions necessary.

- (1) Store the LCD modules in a dark place, do not expose them to sunlight or ultraviolet rays.
- (2) Keep the temperature between 10°C and 35°C at normal humidity.
- (3) Store the LCD modules in the container which is used for shipping from us.
- (4) No articles shall be left on the surfacae over an extended period of time.

11.7 SAFETY

The LCD modules include Cold Cathode Fluorescent Lamp (CFL). CFL contains a small amount of mercury. Please follow local ordinances or regulations for disposal. Wear finger cots or gloves whenever handling or assembling a Touch Panel its glass edges are sharp.

12. DESIGNATION OF LOT MARK

12.1 LOT MARK

Lot mark is consisted of 4 digits for production lot and 6 digits for production control.

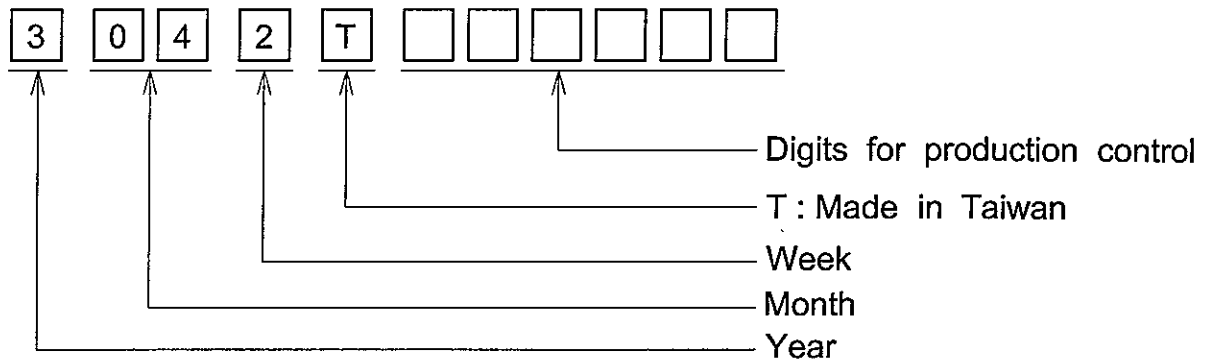

Year	Figure in lot mark
2003	3
2004	4
2005	5
2006	6
2007	7

Month	Figure in lot mark	Month	Figure in lot mark
Jan.	01	Jul.	07
Feb.	02	Aug.	08
Mar.	03	Sep.	09
Apr.	04	Oct.	10
May	05	Nov.	11
Jun.	06	Dec.	12

Week (day in calendar)	Figure in lot mark
1~7	1
8~14	2
15~21	3
22~28	4
29~31	5

12.2 REVISION

REV No.	ITEM	LOT No.	PRODUCTION CONTROL No.
A			000001~

12.3 LOCATION OF LOT MARK

On the back side of LCM.

13. PRECAUTION FOR USE

- (1) A limit sample should be provided by the both parties on an occasion when the both parties agree to its necessity.
Judgement by a limit sample shall take effect after the limit sample has been established and confirmed by the both parties.
- (2) On the following occasions, the handling of the problem should be decided through discussion and agreement between responsible persons of the both parties.
 - (1) When a question is arisen in the specifications.
 - (2) When a new problem is arisen which is not specified in this specifications.
 - (3) When an inspection specifications change or operating condition change by customer is reported to HITACHI, and some problem is arisen in the specification due to the change.
 - (4) Whe a new peoblem is arisen at the customer's operating set for sample evaluation.
- (3) Regarding the treatment for maintenance and repairing, bothl parties will discuss it in six months later after latest delivery of this product.

The precaution that sould be observed when handling LCM have been explained above.

If any points are unclear or if you have any requests, please contact with HITACHI.



element14

EN - For pricing and availability in your local country please visit one of the below links:

DE - Informationen zu Preisen und Verfügbarkeit in Ihrem Land erhalten Sie über die unten aufgeführten Links:

FR - Pour connaître les tarifs et la disponibilité dans votre pays, cliquez sur l'un des liens suivants:

[SX14Q004-ZZA](#)

EN

This Datasheet is presented by
the manufacturer

DE

Dieses Datenblatt wird vom
Hersteller bereitgestellt

FR

Cette fiche technique est
présentée par le fabricant