

KOE

JDI Group

Kaohsiung Opto-Electronics Inc.

FOR MESSRS : _____

DATE : Sep. 30th ,2021

CUSTOMER'S ACCEPTANCE SPECIFICATIONS

TX26D211VM0BAA

Contents

No.	ITEM	SHEET No.	PAGE
1	COVER	7B64PS 2701-TX26D211VM0BAA-1	1-1/1
2	RECORD OF REVISION	7B64PS 2702-TX26D211VM0BAA-1	2-1/1
3	GENERAL DATA	7B64PS 2703-TX26D211VM0BAA-1	3-1/1
4	ABSOLUTE MAXIMUM RATINGS	7B64PS 2704-TX26D211VM0BAA-1	4-1/1
5	ELECTRICAL CHARACTERISTICS	7B64PS 2705-TX26D211VM0BAA-1	5-1/3~3/3
6	OPTICAL CHARACTERISTICS	7B64PS 2706-TX26D211VM0BAA-1	6-1/2~2/2
7	BLOCK DIAGRAM	7B64PS 2707-TX26D211VM0BAA-1	7-1/1
8	RELIABILITY TESTS	7B64PS 2708-TX26D211VM0BAA-1	8-1/1
9	LCD INTERFACE	7B64PS 2709-TX26D211VM0BAA-1	9-1/7~7/7
10	OUTLINE DIMENSIONS	7B64PS 2710-TX26D211VM0BAA-1	10-1/2~2/2
11	APPEARANCE STANDARD	7B64PS 2711-TX26D211VM0BAA-1	11-1/3~3/3
12	PRECAUTIONS	7B64PS 2712-TX26D211VM0BAA-1	12-1/2~2/2
13	DESIGNATION OF LOT MARK	7B64PS 2713-TX26D211VM0BAA-1	13-1/1

ACCEPTED BY: _____

PROPOSED BY: Oblack Tsai

2. RECORD OF REVISION

DATE	SHEET No.	SUMMARY

3. GENERAL DATA

3.1 DISPLAY FEATURES

This module is a 10.4" XGA of 4:3 format of amorphous silicon TFT. The pixel format is vertical stripe and sub pixels are arranged as R (red), G (green), B (blue) sequentially. This display is RoHS compliant, COG (chip on glass) technology and LED backlight are applied on this display.

Part Name	TX26D211VM0BAA
Module Dimensions	230 (W) mm x 180.2(H) mm x 9.5 (D) mm
LCD Active Area	211.2(W) mm x 158.4(H)
Pixel Pitch	0.20625(W) mm x 0.20625 (H)
Resolution	1024 x 3(RGB)(W) x 768(H) dots
Color Pixel Arrangement	R, G, B Vertical Stripe
LCD Type	Transmissive Color TFT; Normally Black
Display Type	Active Matrix
Number of Colors	16.7M Colors(8 bit RGB)
Backlight	Light Emitting Diode (LED)
Weight	410g
Interface	1ch-LVDS ; 20 pins
Power Supply Voltage	3.3V for LCD; 12V for Backlight
Power Consumption	1.0W for LCD; 8.6W for Backlight
Viewing Direction	Super Wide Version (In-Plane Switching)

4. ABSOLUTE MAXIMUM RATINGS

Item	Symbol	Min.	Max.	Unit	Remarks
Supply Voltage	V _{DD1}	-0.3	3.9	V	-
Input Voltage of Logic	V _I	-0.3	V _{DD} +0.3	V	Note 1
Operating Temperature	T _{op}	-30	80	°C	Note 2
Storage Temperature	T _{st}	-40	80	°C	Note 2
Backlight Input Voltage	V _{LED}	-0.3	14	V	-
Backlight Voltage for PWM	V _{PWM}	-0.3	14	V	-
Backlight Voltage for EN	V _{EN}	-0.3	14	V	-

Note 1: The rating is defined for the signal voltages of the interface such as CLK and pixel data pairs.

Note 2: The maximum rating is defined as above based on the glass surface temperature, which might be different from ambient temperature after assembling the panel into the application.

Moreover, some temperature-related phenomenon as below needed to be noticed:

- Background color, contrast and response time would be different in temperatures other than 25 °C.
- Operating under high temperature will shorten LED lifetime.

5. ELECTRICAL CHARACTERISTICS

5.1 DC CHARACTERISTICS OF GENERAL

$T_a = 25\text{ }^\circ\text{C}$, GND = 0V

Item	Symbol	Condition	Standard Value			Unit	Remarks
			Min.	Typ.	Max.		
Power supply voltage	V_{DD1}	-	3.0	3.3	3.6	V	-
Power supply current	I_{DD1}	$V_{DD}=3.3\text{V}$	-	300	400	mA	Note 1,5
Allowable Ripple Voltage	VRP1	-	-	-	100	mV (p-p)	-
Input signal voltage	V_{IH1}	-	$0.7V_{DD}$	-	V_{DD}	V	Note 2
	V_{IL1}	-	V_{SS}	-	$0.3V_{DD}$	V	
Differential Input High Threshold	V_{TH}	$V_{ICM}=1.2\text{V}$	-	-	100	mV	
Differential Input Low Threshold	V_{TL}	$V_{ICM}=1.2\text{V}$	-100	-	-	mV	
Input Differential Voltage	$ VID $	-	200	-	600	mV	
Differential Input Common Mode Voltage	VCM	$ VID /2$	-	1.2	-	V	

Note 1: An All white check pattern is used when measuring I_{DD} frame rate is set to 60Hz with Typ voltage.

Note 2: For LVDS input signal.

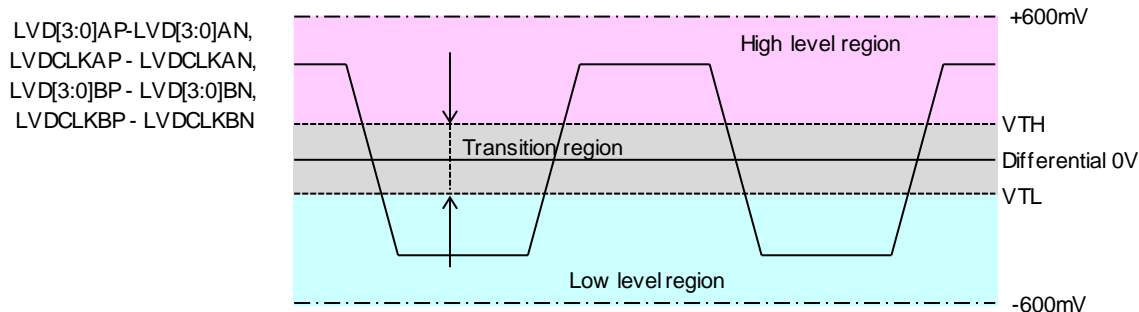
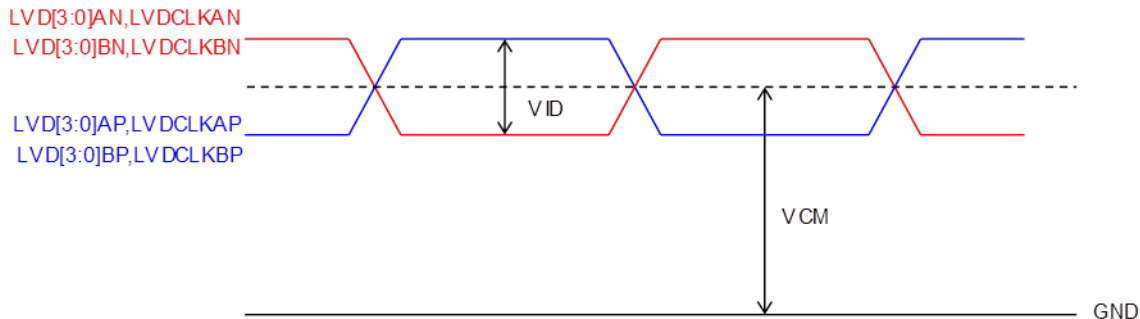

Note 3: (2A) fuse is applied in the module for I_{DD} . For display activation and protection purpose, power supply is recommended larger than (5A) to start the display and break fuse once any short circuit occurred.

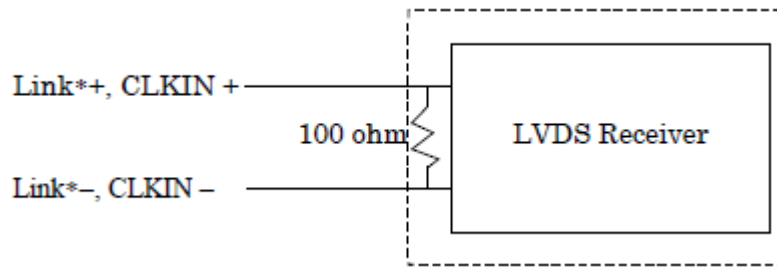

5.2 BACKLIGHT CHARACTERISTICS

$T_a = 25^\circ\text{C}$

Item	Symbol	Condition	Min.	Typ.	Max.	Unit	Remarks
LED Input Voltage	V_{LED}	$I_{LED} = 720\text{mA}$	10.8	12	13.2	V	Note 1
LED Forward Current	I_{LED}	100% duty	-	720	-	mA	Note 2
		0% duty	-	0.01	-		
PWM Signal Voltage	-	High	2.5	-	V_{LED}	V	-
		Low	-	-	0.4		
EN Voltage	V_{EN}	-	2.5	-	5.5	V	-
LED Lifetime	-	$I_{LED} = 720\text{mA}$	-	100K	-	hrs	Note 3

Note 1: Fig. 5.1 shows the LED backlight circuit.

Note 2: Dimming function can be obtained by applying PWM signal from the display interface CN2. The recommended PWM signal is 100Hz ~ 5KHz with 3.3 V amplitude.

Note 3: The estimated lifetime is specified as the time to reduce 50% brightness by applying 720 mA at 25°C .

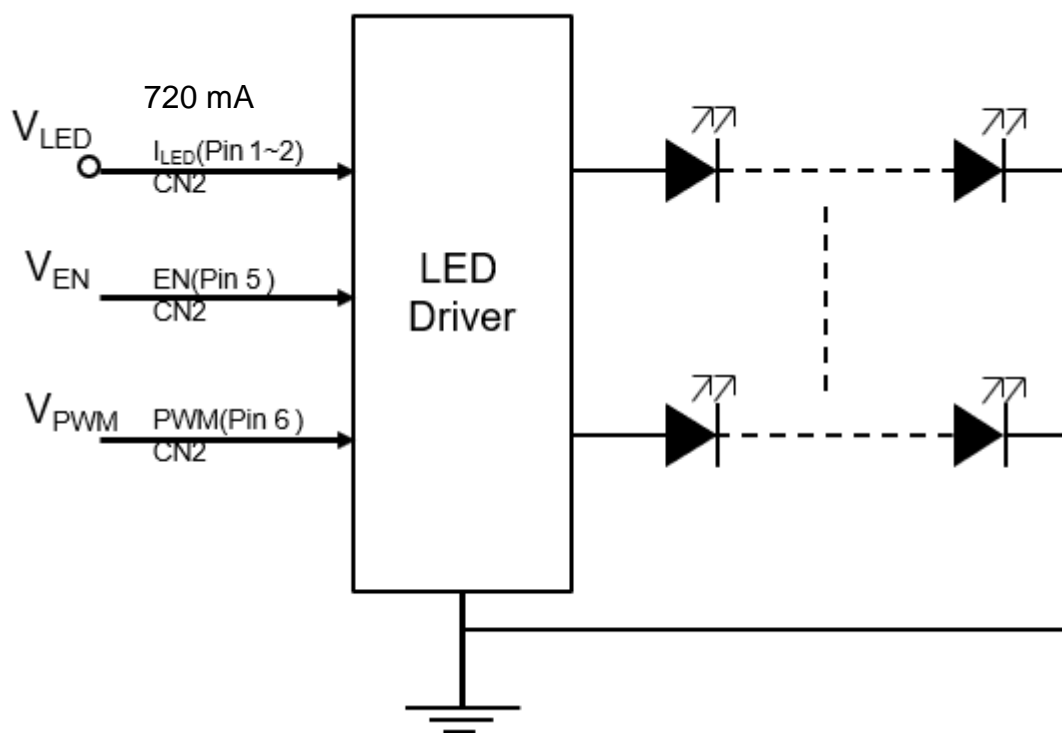

Fig 5.1

6. OPTICAL CHARACTERISTICS

The optical characteristics are measured based on the conditions as below:

- Supplying the signals and voltages defined in the section of electrical characteristics.
- The backlight unit needs to be turned on for 30 minutes.
- The ambient temperature is 25 °C .
- In the dark room less than 100 lx, the equipment has been set for the measurements as shown in Fig 6.1.

$$T_a = 25 \text{ }^\circ\text{C}, f_{Frame} = 60 \text{ Hz}, V_{DD} = 3.3\text{V}$$

Item	Symbol	Condition	Min.	Typ.	Max.	Unit	Remarks	
Brightness of White	-	$\phi = 0^\circ, \theta = 0^\circ$, $I_{LED} = 720 \text{ mA}$	1000	1300	-	cd/m ²	Note 1	
Brightness Uniformity	-		70	80	-	%	Note 2	
Contrast Ratio	CR		500	1000	-	-	Note 3	
Response Time	$T_r + T_f$	$\phi = 0^\circ, \theta = 0^\circ$	-	30	-	ms	Note 4	
NTSC Ratio	-	$\phi = 0^\circ, \theta = 0^\circ$	-	70	-	%	-	
Viewing Angle	θ_x	$\phi = 0^\circ, CR \geq 10$	-	85	-	Degree	Note 5	
	$\theta_{x'}$	$\phi = 180^\circ, CR \geq 10$	-	85	-			
	θ_y	$\phi = 90^\circ, CR \geq 10$	-	85	-			
	$\theta_{y'}$	$\phi = 270^\circ, CR \geq 10$	-	85	-			
Color Chromaticity	Red	X	$\phi = 0^\circ, \theta = 0^\circ$	0.599	0.649	0.699	-	Note 6
		Y		0.294	0.344	0.394		
	Green	X		0.268	0.318	0.368		
		Y		0.572	0.622	0.672		
	Blue	X		0.097	0.147	0.197		
		Y		0.045	0.095	0.145		
	White	X		0.261	0.311	0.361		
		Y		0.294	0.344	0.394		

Note 1: The brightness is measured from the center point of the panel, P5 in Fig. 6.2, for the typical value.

Note 2: The brightness uniformity is calculated by the equation as below:

$$\text{Brightness uniformity} = \frac{\text{Min. Brightness}}{\text{Max. Brightness}} \times 100\%$$

which is based on the brightness values of the 9 points in active area measured by BM-5 as shown in Fig. 6.2.

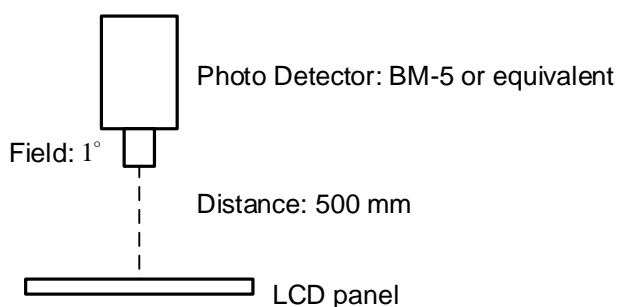

Fig 6.1

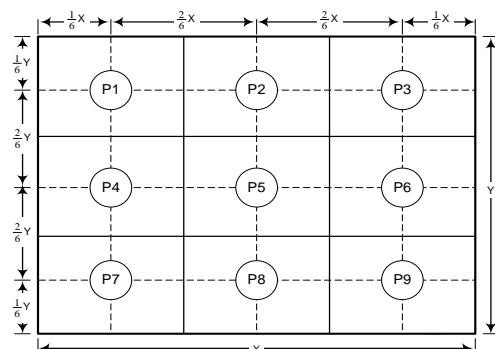

Fig 6.2

Note 3: The Contrast Ratio is measured from the center point of the panel, P5, and defined as the following equation:

$$CR = \frac{\text{Brightness of White}}{\text{Brightness of Black}}$$

Note 4: The definition of response time is shown in Fig. 6.3. The rising time is the period from 10% brightness to 90% brightness when the data is from black to white. Oppositely, Falling time is the period from 90% brightness falling to 10% brightness.

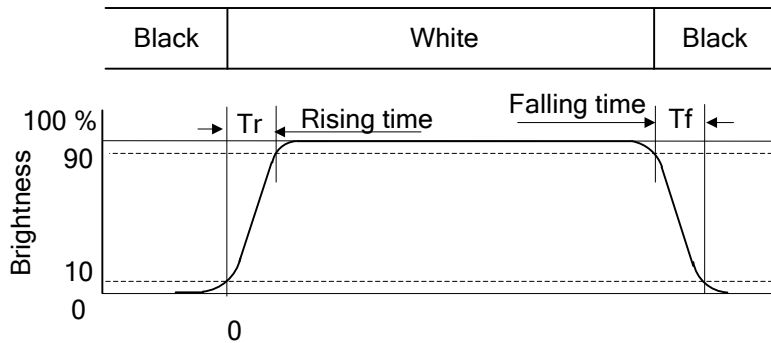

Fig 6.3

Note 5: The definition of viewing angle is shown in Fig. 6.4. Angle ϕ is used to represent viewing directions, for instance, $\phi = 270^\circ$ means 6 o'clock, and $\phi = 0^\circ$ means 3 o'clock. Moreover, angle θ is used to represent viewing angles from axis Z toward plane XY.

The display is super wide viewing angle version; 85° viewing angle can be obtained from each viewing direction.

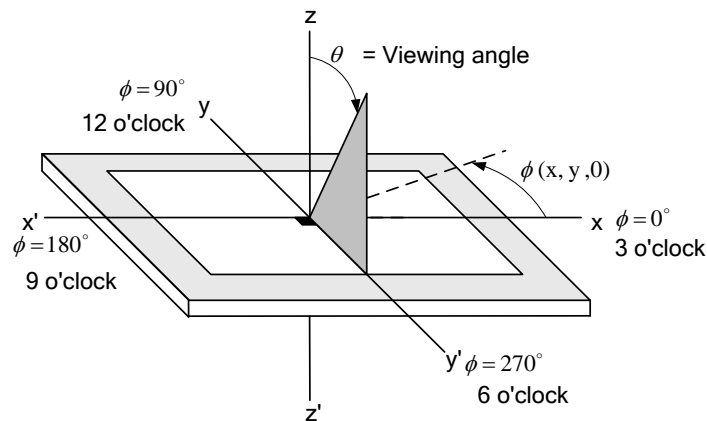
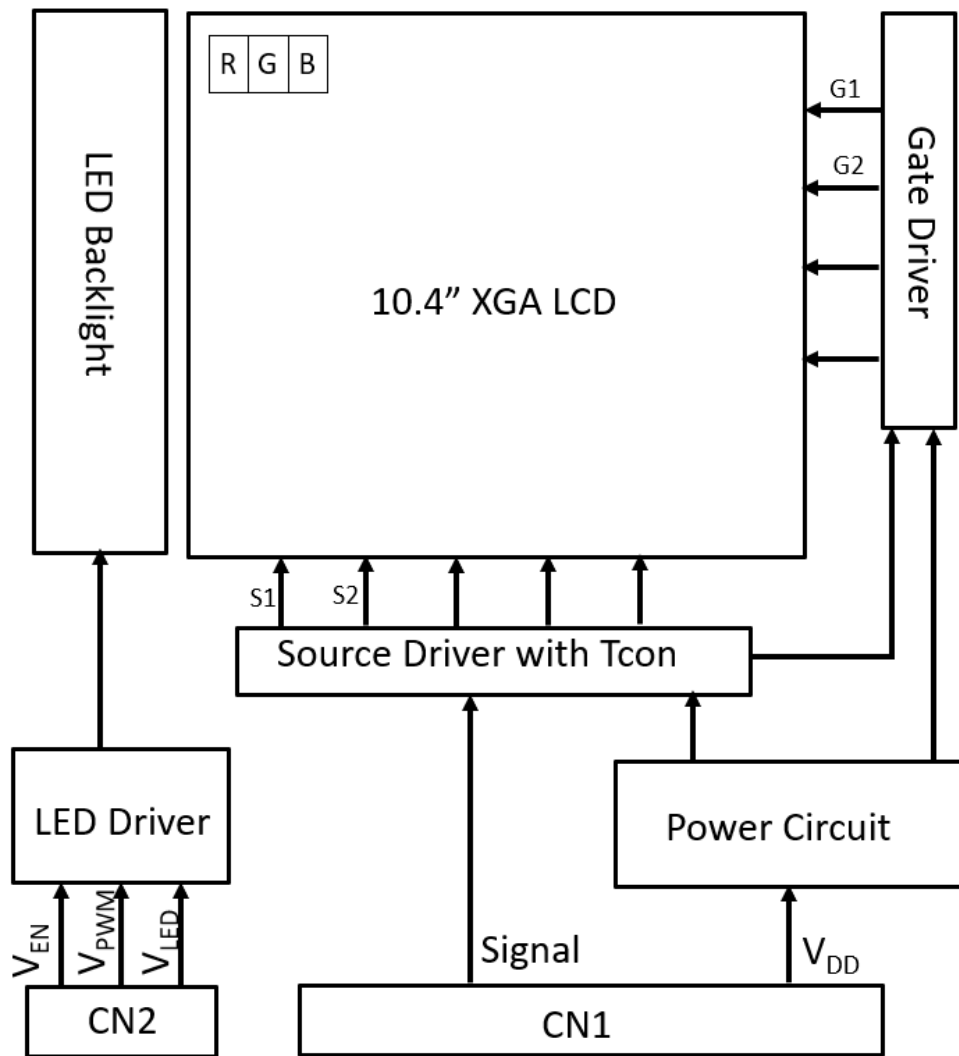

Fig 6.4

Note 6: The color chromaticity is measured from the center point of the panel, P5, as shown in Fig. 6.2.

7. BLOCK DIAGRAM



Note 1: Signals are CLK and pixel data pairs.

8. RELIABILITY TESTS

Test Item	Condition	
High Temperature	1) Operating 2) 80 °C	240 hrs
Low Temperature	1) Operating 2) -30 °C	240 hrs
High Temperature	1) Storage 2) 80 °C	240 hrs
Low Temperature	1) Storage 2) -40 °C	240 hrs
Thermal Shock	1) Non-Operating 2) -30 °C ↔ 80 °C 3) 0.5 hr ↔ 0.5 hr	240 hrs
High Temperature & Humidity	1) Operating 2) 65 °C & 85%RH 3) Without condensation	240 hrs (Note 3)
Vibration	1) Non-Operating 2) 20~300 Hz 3) 6.8G 4) X, Y, and Z directions	1 hr for each direction
Mechanical Shock	1) Non-Operating 2) 10 ms 3) 50G 4) ±X, ±Y and ±Z directions	Once for each direction
ESD	1) Operating 2) Tip: 150 pF, 330 Ω 3) Air discharge for glass: ±8KV 4) Contact discharge for metal frame: ±8KV	1) Glass: 9 points 2) Metal frame: 8 points (Note4)

Note 1: Display functionalities are inspected under the conditions defined in the specification after the reliability tests.

Note 2: The display is not guaranteed for use in corrosive gas environments.

Note 3: Under the condition of high temperature & humidity, if the temperature is higher than 40 °C, the humidity needs to be reduced as Fig. 8.1 shown.

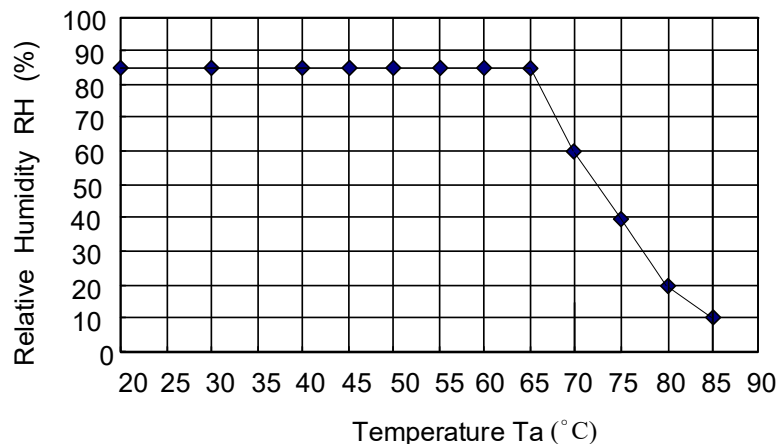

Fig. 8.1

Note 4: All pins of LCD interface (CN1) have been tested by ±100V contact discharge of ESD under non-operating condition.

9. LCD INTERFACE

9.1 INTERFACE PIN CONNECTIONS

The display interface connector CN1 is 20186-020E-11F (I-PEX), and Pin assignment is as below:

No.	Signal	Signal	I/O/P	Note
1	V _{DD}	Power supply for LCD	I	
2	VDD	Power supply for LCD	I	
3	GND	GND	P	
4	GND	GND	P	
5	IN0-	R0~R5, G0	I	
6	IN0+	R0~R5, G0	I	
7	GND	GND	P	
8	IN1-	G1~G5, B0~B1	I	
9	IN1+	G1~G5, B0~B1	I	
10	GND	GND	P	
11	IN2-	B2~B5, DE	I	
12	IN2+	B2~B5, DE	I	
13	GND	GND	P	
14	CLK IN-	Pixel Clock	I	
15	CLK IN+	Pixel Clock	I	
16	GND	GND	P	
17	IN3-	R6~R7, G6~G7, B6~B7	I	
18	IN3+	R6~R7, G6~G7, B6~B7	I	
19	NC	No Connection	-	
20	SC	Scan direction control (Normal : Low or Default. Reverse : High)	I	Note 1

Note 1: Scan direction is available to be switched as below.



Normal : Low or Default



Reverse : High

The interface CN2 is (3800K-F06N-03L) made by E&T and pin assignment is as below:

Connector Name	Pin No.	Symbol	Function
3800K-F06N-03L	1	V _{LED(+)}	Power Supply for LED (12V)
	2	V _{LED(+)}	Power Supply for LED (12V)
	3	V _{LED(-)}	GND
	4	V _{LED(-)}	GND
	5	V _{EN}	Backlight Enable
	6	V _{PWM}	Brightness dimming(Note1,2)

Note 1: The relationship of brightness and Dim control are shown as below.

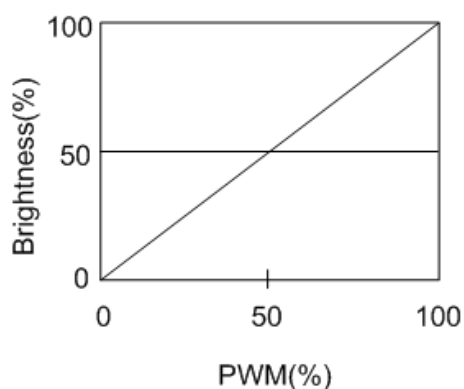

Note 2: Normal brightness : 100% PWM duty ; Brightness control : 0% to 100% PWM duty. If no using , please keep it high(100%).

9.2 DATA INPUT TIMING

The column of timing sets including minimum, typical, and maximum as below are based on the best optical performance, frame frequency (f_{Frame}) =60Hz to define. If 60Hz is not the aim to set, Less than 66Hz for f_{Frame} is recommended to apply for better other parameter combination as the definitions in section 5.2.

Parameter	Symbol	Min.	Typ.	Max.	Unit	
Clock	Frequency	fCLK	60.8	65.0	69.0	MHz
Vertical timing	Frequency	fVD	55.0	60.0	65.0	Hz
	Cycle	tV	796.0	806.0	816.0	Line
	Display period	tVD	768.0	768.0	768.0	Line
Horizontal timing	Cycle	tH	1244.0	1344.0	1444.0	CLK
	Display period	tHD	1024.0	1024.0	1024.0	CLK

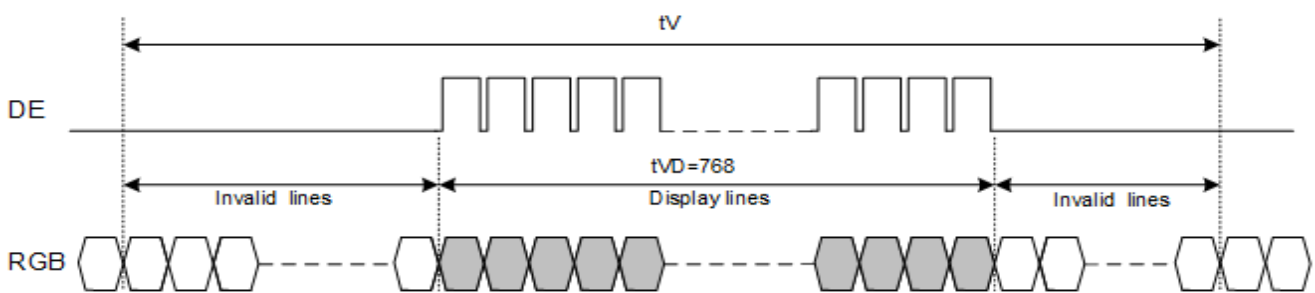

Vertical timing

Note : In case of changing the vertical and horizontal timing, the display should be turned off.

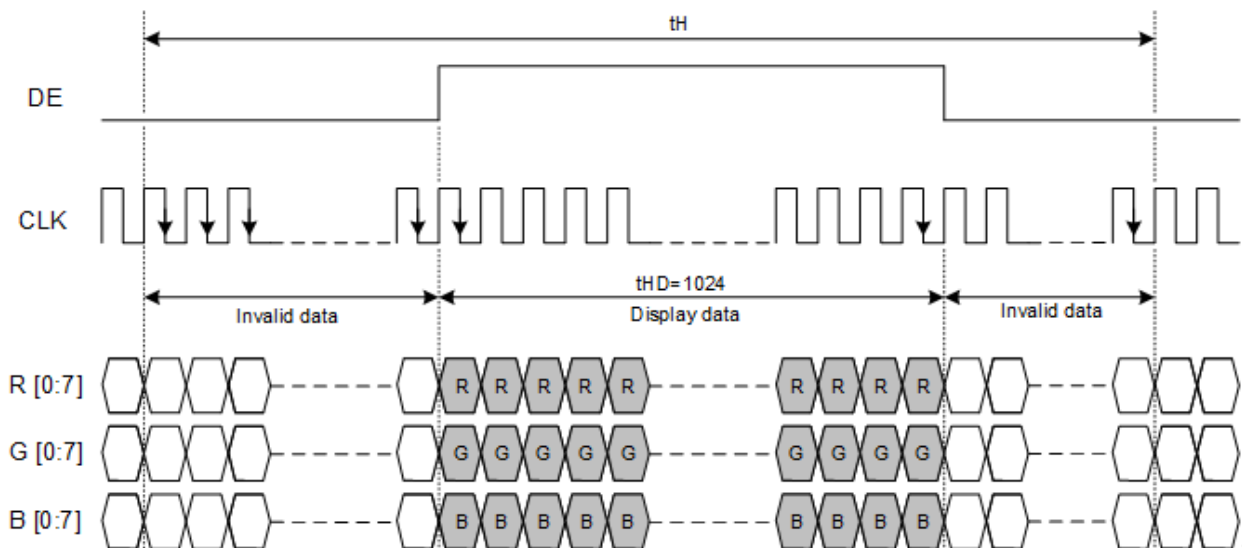

Horizontal timing

Note : In case of changing the vertical and horizontal timing, the display should be turned off.

9.3 LVDS DATA FORMAT

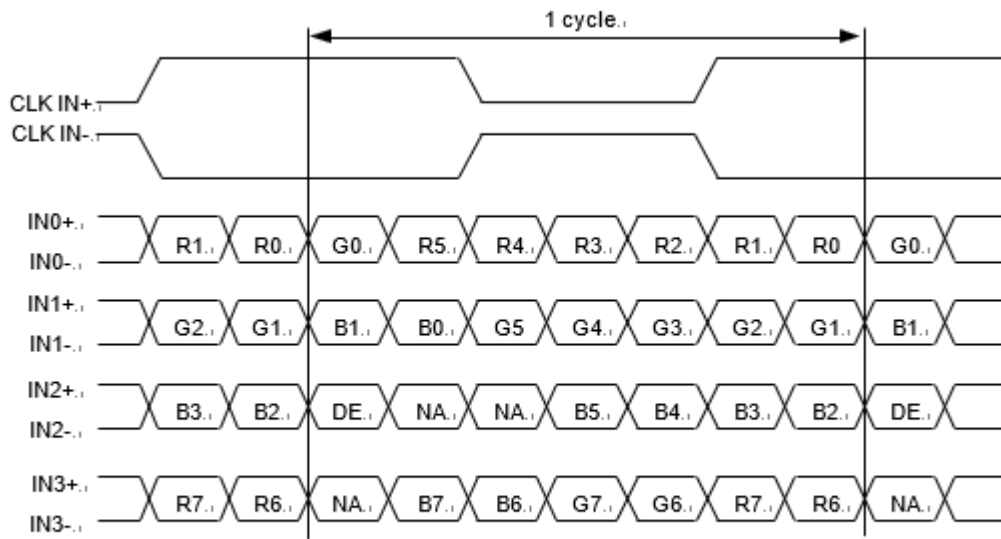

DE: Display Enable

NA: Not Available

8bit LVDS input

9.4 LVDS RECEIVER TIMING

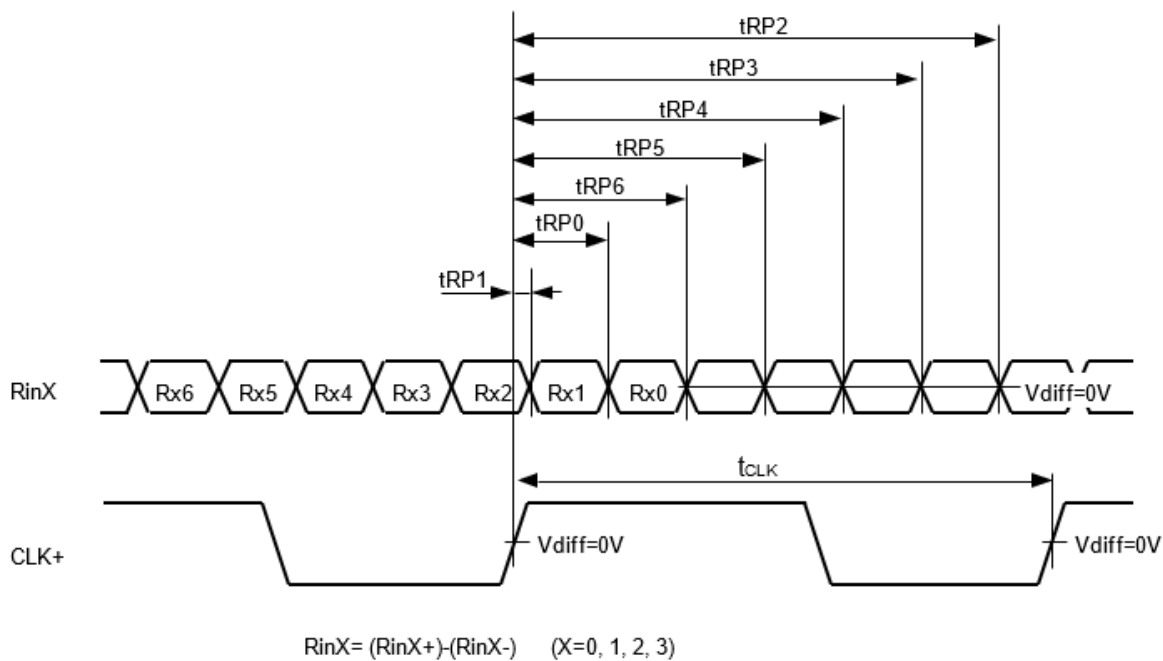

	Item	Symbol	Min.	Typ.	Max.	Unit
CLK	Cycle frequency	$1/t_{CLK}$	60.8	65	69	MHz
R_{inX} ($X=0,1,2,3$)	0 data position	t_{RP0}	-	$1/7 * t_{CLK}$	-	ns
	1st data position	t_{RP1}	-0.2	0	0.2	
	2nd data position	t_{RP2}	-0.2	$6/7 * t_{CLK}$	0.2	
	3rd data position	t_{RP3}	-0.2	$5/7 * t_{CLK}$	0.2	
	4th data position	t_{RP4}	-0.2	$4/7 * t_{CLK}$	0.2	
	5th data position	t_{RP5}	-0.2	$3/7 * t_{CLK}$	0.2	
	6th data position	t_{RP6}	-0.2	$2/7 * t_{CLK}$	0.2	

9.5 DATA INPUT for DISPLAYCOLOR

8bit mode

Input color		Red Data								Green Data								Blue Data													
		R7	R6	R5	R4	R3	R2	R1	R0	G7	G6	G5	G4	G3	G2	G1	G0	B7	B6	B5	B4	B3	B2	B1	B0						
		MSB								LSB								MSB								LSB					
Basic Color	Black	0	0	0	0	0	0	0	0	0	0	0	0	0	0	0	0	0	0	0	0	0	0	0	0						
	Red(255)	1	1	1	1	1	1	1	1	0	0	0	0	0	0	0	0	0	0	0	0	0	0	0							
	Green(255)	0	0	0	0	0	0	0	0	1	1	1	1	1	1	1	0	0	0	0	0	0	0	0							
	Blue(255)	0	0	0	0	0	0	0	0	0	0	0	0	0	0	0	1	1	1	1	1	1	1	1							
	Cyan	0	0	0	0	0	0	0	0	1	1	1	1	1	1	1	1	1	1	1	1	1	1	1							
	Magenta	1	1	1	1	1	1	1	1	0	0	0	0	0	0	0	1	1	1	1	1	1	1	1							
	Yellow	1	1	1	1	1	1	1	1	1	1	1	1	1	1	1	0	0	0	0	0	0	0	0							
	White	1	1	1	1	1	1	1	1	1	1	1	1	1	1	1	1	1	1	1	1	1	1	1							
Red	Black	0	0	0	0	0	0	0	0	0	0	0	0	0	0	0	0	0	0	0	0	0	0								
	Red(1)	0	0	0	0	0	0	0	1	0	0	0	0	0	0	0	0	0	0	0	0	0	0								
	Red(2)	0	0	0	0	0	0	1	0	0	0	0	0	0	0	0	0	0	0	0	0	0	0								
	:	:	:	:	:	:	:	:	:	:	:	:	:	:	:	:	:	:	:	:	:	:	:								
	:	:	:	:	:	:	:	:	:	:	:	:	:	:	:	:	:	:	:	:	:	:	:								
	Red(253)	1	1	1	1	1	1	0	1	0	0	0	0	0	0	0	0	0	0	0	0	0	0								
	Red(254)	1	1	1	1	1	1	1	0	0	0	0	0	0	0	0	0	0	0	0	0	0	0								
Red(255)	1	1	1	1	1	1	1	0	0	0	0	0	0	0	0	0	0	0	0	0	0	0									
Green	Black	0	0	0	0	0	0	0	0	0	0	0	0	0	0	0	0	0	0	0	0	0	0								
	Green(1)	0	0	0	0	0	0	0	0	0	0	0	0	0	1	0	0	0	0	0	0	0	0								
	Green(2)	0	0	0	0	0	0	0	0	0	0	0	0	1	0	0	0	0	0	0	0	0	0								
	:	:	:	:	:	:	:	:	:	:	:	:	:	:	:	:	:	:	:	:	:	:	:								
	:	:	:	:	:	:	:	:	:	:	:	:	:	:	:	:	:	:	:	:	:	:	:								
	Green(253)	0	0	0	0	0	0	0	1	1	1	1	1	1	0	1	0	0	0	0	0	0	0								
	Green(254)	0	0	0	0	0	0	0	1	1	1	1	1	1	1	0	0	0	0	0	0	0	0								
Green(255)	0	0	0	0	0	0	0	1	1	1	1	1	1	1	0	0	0	0	0	0	0	0									
Blue	Black	0	0	0	0	0	0	0	0	0	0	0	0	0	0	0	0	0	0	0	0	0	0								
	Blue(1)	0	0	0	0	0	0	0	0	0	0	0	0	0	0	0	0	0	0	0	0	0	1								
	Blue(2)	0	0	0	0	0	0	0	0	0	0	0	0	0	0	0	0	0	0	0	0	1	0								
	:	:	:	:	:	:	:	:	:	:	:	:	:	:	:	:	:	:	:	:	:	:	:								
	:	:	:	:	:	:	:	:	:	:	:	:	:	:	:	:	:	:	:	:	:	:	:								
	Blue(253)	0	0	0	0	0	0	0	0	0	0	0	0	0	0	1	1	1	1	1	1	0	1								
	Blue(254)	0	0	0	0	0	0	0	0	0	0	0	0	0	0	1	1	1	1	1	1	1	0								
Blue(255)	0	0	0	0	0	0	0	0	0	0	0	0	0	0	1	1	1	1	1	1	1	1									

9.6 POWER ON / OFF SEQUENCE

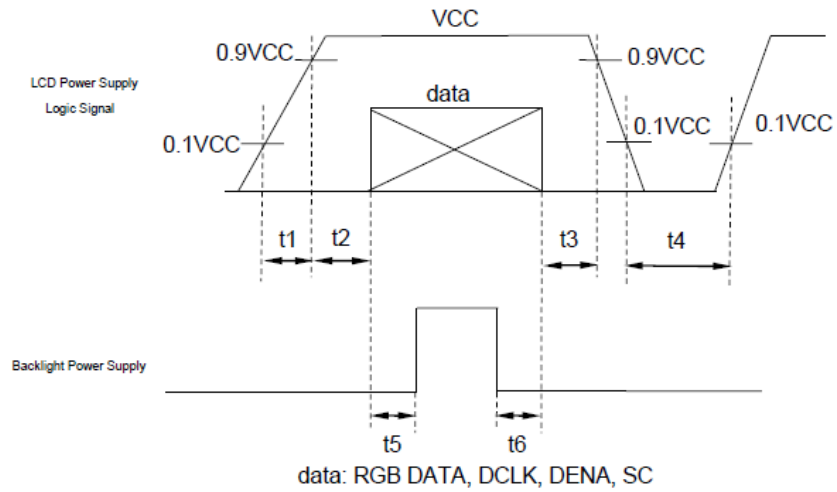

Please design the circuit which is able to adjust the interval of following table.

	't1	't2	't3	't4	't5	't6
Min.	$0.5 \text{ ms} \leq$	$0 <$	$0 <$	$500\text{ms} \leq$	$200\text{ms} \leq$	$0 \leq$
Max.	$\leq 10 \text{ ms}$	$\leq 50 \text{ ms}$	$\leq 50\text{ms}$	-	-	-

10. OUTLINE DIMENSIONS

10.1 FRONT VIEW

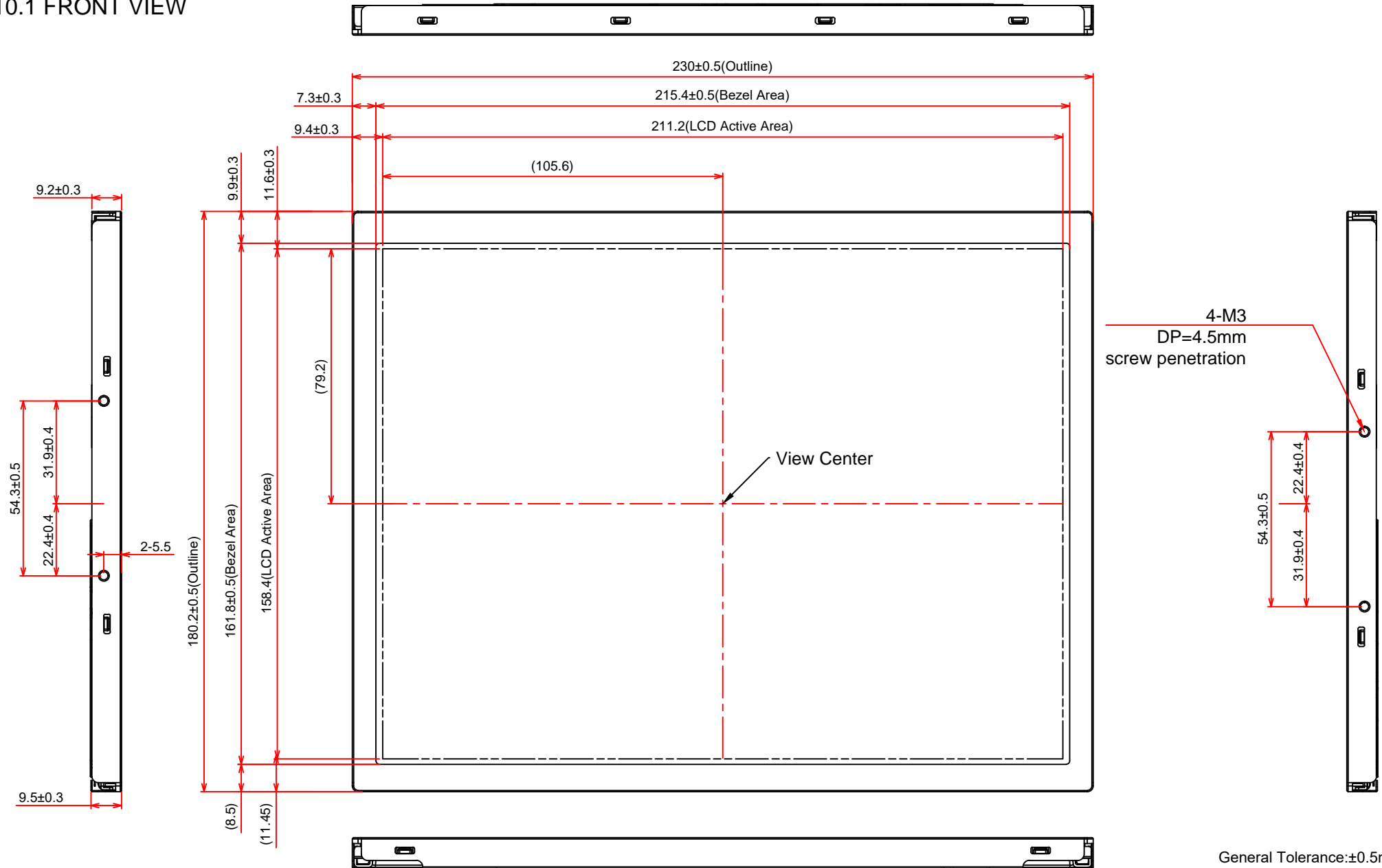

General Tolerance:±0.5mm
Scale : NTS
Unit : mm

10.2 REAR VIEW

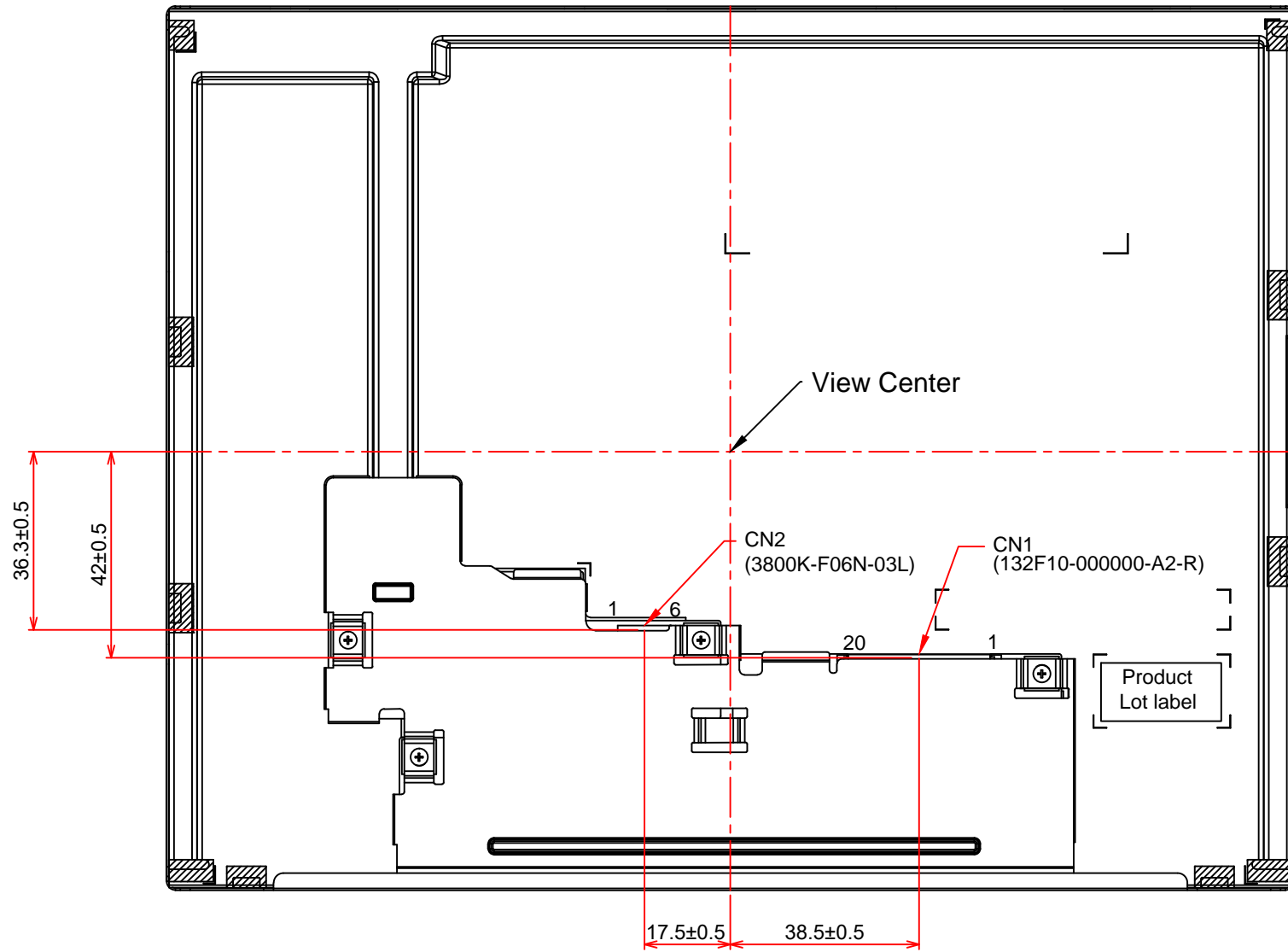

General Tolerance: ± 0.5 mm
 Scale : NTS
 Unit : mm

11. APPEARANCE STANDARD

The appearance inspection is performed in a dark room around 500~1000 lx based on the conditions as below:

- The distance between inspector's eyes and display is 30 cm. ambient temperature is $25^{\circ}\text{C}\pm 5^{\circ}\text{C}$.
- The viewing zone is defined with angle θ shown in Fig. 11.1 The inspection should be performed within 45° when display is shut down. The inspection should be performed within 5° when display is power on.

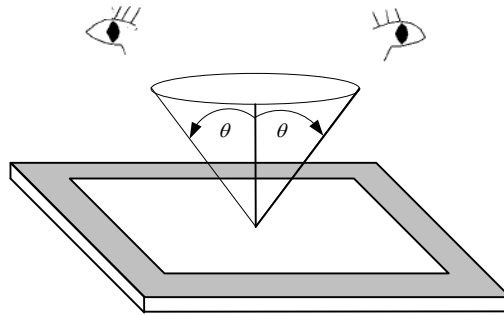

Fig. 11.1

11.1 THE DEFINITION OF LCD ZONE

LCD panel is divided into 3 areas as shown in Fig.11.2 for appearance specification in next section. A zone is the LCD active area (dot area); B zone is the area, which extended 1 mm out from LCD active area; C zone is the area between B zone and metal frame.

In terms of housing design, B zone is the recommended window area customers' housing should be located in.

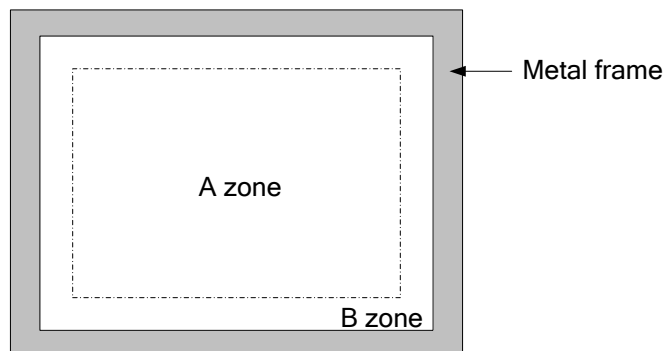

Fig. 11.2

11.2 LCD APPEARANCE SPECIFICATION

The specification as below is defined as the amount of unexpected phenomenon or material in different zones of LCD panel. The definitions of length, width and average diameter using in the table are shown in Fig. 11.3 and Fig. 11.4.

Item	Criteria				Applied zone
	Length (mm)	Width (mm)	Maximum number	Minimum space	
Scratches	Ignored	$W \leq 0.05$	Ignored	-	A, B
	$1 \leq L \leq 5.0$	$0.05 < W \leq 0.2$	4	-	
	-	$0.2 < W$	Not allowed	-	
	Serious one is not allowed				
Dent	Serious one is not allowed				A
Wrinkles in polarizer	Serious one is not allowed				A
Bubbles on polarizer	Average diameter (mm)		Maximum number		A
	$D \leq 0.05$		Ignored		
	$0.15 < D \leq 0.5$		3		
	$0.5 < D$		Not allowed		
1) Stains 2) Foreign Materials 3) Dark Spot	Filamentous (Line shape)				A, B
	Length (mm)	Width (mm)	Maximum number		
	-	$W \leq 0.05$	Ignored		
	$0.3 \leq L \leq 2.0$	$0.05 < W \leq 0.1$	5		
	$L < 2$	$0.1 < W$	Not allowed		
	Round (Dot shape)				A, B
	Average diameter (mm)		Maximum number	Minimum Space	
	$D \leq 0.15$		Ignored	-	
	$0.15 < D \leq 0.5$		5	-	
	$0.5 < D$		Not allowed	-	
	Those wiped out easily are acceptable				
	Dot-Defect (Note 1)			Type	Maximum number
Bright dot-defect		1 dot	0		
Dark dot-defect		1 dot	4		
		2 adjacent dot	Not allowed		
		3 adjacent dot or above	Not allowed		
		In total	4		
Minimum distance between dark dots			$\geq 50\text{mm}$		
In total			4		
Mura	Invisible through 2% ND filter				A (Note 2)

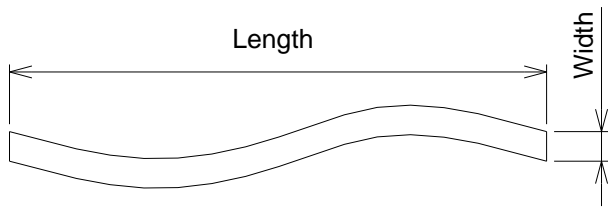

Fig 11.3

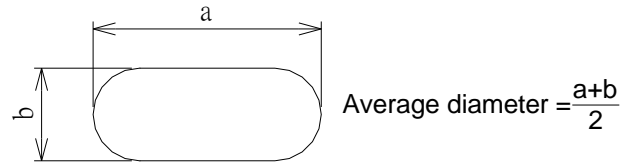

Fig 11.4

Note 1: The definitions of dot defect are as below:

- For bright dot-defect, showing black pattern, visible with 5% ND filter is defined.
- For bright dot-defect, dark dot-defect, showing white pattern, defect size over 1/2 dot area is defined.
- The definition of 1-dot-defect is the defect-dot, which is isolated and no adjacent defect-dot.
- The definition of adjacent dot is shown as Fig. 11.5.
- The Density of dot defect is defined in the area within diameter $\phi = 50\text{mm}$.

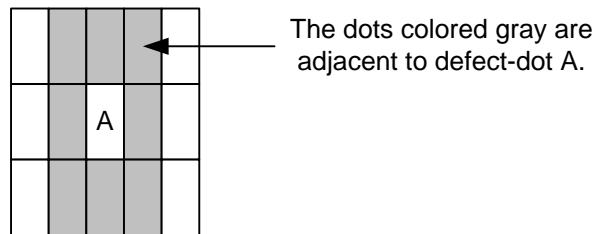
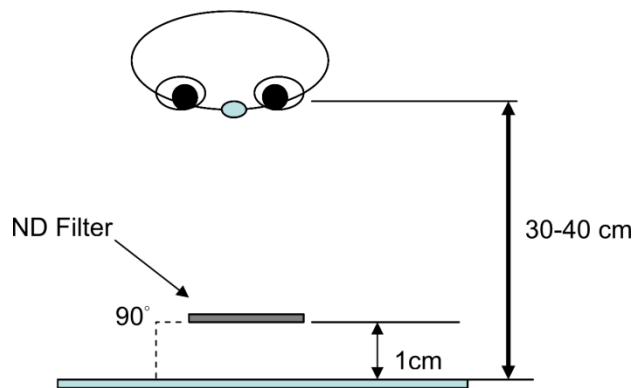

Fig. 11.5

Note 2: The inspection method with ND Filter is to hold it in front of the panel around 1 cm and inspect the panel with 35±5 cm distance for 1 second.



12. PRECAUTIONS

12.1 PRECAUTIONS of ESD

- 1) Before handling the display, please ensure your body has been connected to ground to avoid any damages by ESD. Also, do not touch display's interface directly when assembling.
- 2) Please remove the protection film very slowly before turning on the display to avoid generating ESD.

12.2 PRECAUTIONS of HANDLING

- 1) In order to keep the appearance of display in good condition, please do not rub any surfaces of the displays by sharp tools harder than 3H, especially touch panel, metal frame and polarizer.
- 2) Please do not pile the displays in order to avoid any scars leaving on the display. In order to avoid any injuries, please pay more attention for the edges of glasses and metal frame, and wear finger cots to protect yourself and the display before working on it.
- 3) Touching the display area or the terminal pins with bare hand is prohibited. This is because it will stain the display area and cause poor insulation between terminal pins, and might affect display's electrical characteristics furthermore.
- 4) Do not use any harmful chemicals such as acetone, toluene, and isopropyl alcohol to clean display's surfaces.
- 5) Please use soft cloth or absorbent cotton with ethanol to clean the display by gently wiping. Moreover, when wiping the display, please wipe it by horizontal or vertical direction instead of circling to prevent leaving scars on the display's surface, especially polarizer.
- 6) Please wipe any unknown liquids immediately such as saliva, water or dew on the display to avoid color fading or any permanently damages.
- 7) Maximum pressure to the surface of the display must be less than 1.96×10^4 Pa. If the area of adding pressure is less than 1 cm^2 , the maximum pressure must be less than 1.96N.

12.3 PRECAUTIONS OF OPERATING

- 1) Please input signals and voltages to the displays according to the values defined in the section of electrical characteristics to obtain the best performance. Any voltages over than absolute maximum rating will cause permanent damages to this display. Also, any timing of the signals out of this specification would cause unexpected performance.
- 2) When the display is operating at significant low temperature, the response time will be slower than it at 25 C° . In high temperature, the color will be slightly dark and blue compared to original pattern. However, these are temperature-related phenomenon of LCD and it will not cause permanent damages to the display when used within the operating temperature.
- 3) The use of screen saver or sleep mode is recommended when static images are likely for long periods of time. This is to avoid the possibility of image sticking.
- 4) Spike noise can cause malfunction of the circuit. The recommended limitation of spike noise is no bigger than $\pm 100 \text{ mV}$.

12.4 PRECAUTIONS of STORAGE

If the displays are going to be stored for years, please be aware the following notices.

- 1) Please store the displays in a dark room to avoid any damages from sunlight and other sources of UV light.
- 2) The recommended long term storage temperature is between 10 C° ~35 C° and 55%~75% humidity to avoid causing bubbles between polarizer and LCD glasses, and polarizer peeling from LCD glasses.
- 3) It would be better to keep the displays in the container, which is shipped from KOE, and do not unpack it.
- 4) Please do not stick any labels on the display surface for a long time, especially on the polarizer.

13. DESIGNATION of LOT MARK

1) The lot mark is showing in Fig.13.1. First 4 digits are used to represent production lot, T represented made in Taiwan, and the last 6 digits are the serial number.

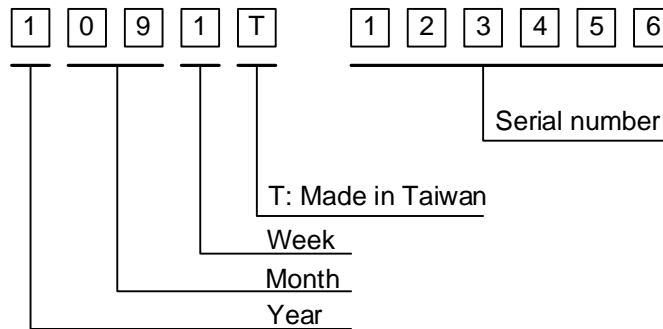

Fig. 13.1

2) The tables as below are showing what the first 4 digits of lot mark are shorted for.

Year	Lot Mark
2021	1
2022	2
2023	3
2024	4
2025	5

Month	Lot Mark	Month	Lot Mark
Jan.	01	Jul.	07
Feb.	02	Aug.	08
Mar.	03	Sep.	09
Apr.	04	Oct.	10
May	05	Nov.	11
Jun.	06	Dec.	12

Week	Lot Mark
1~7 days	1
8~14 days	2
15~21 days	3
22~28 days	4
29~31 days	5

3) Except letters I and O, revision number will be shown on lot mark and following letters A to Z.

REV No.	ITEM	REMARKS
A	-	-

4) The location of the lot mark is on the back of the display shown in Fig. 13.2.

Label example:

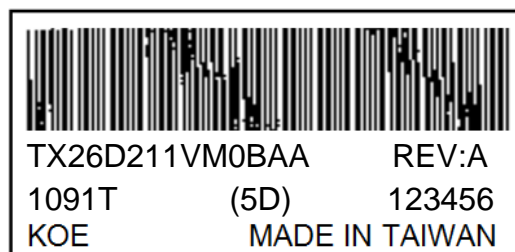

Fig. 13.2